

TECHNICAL CARD



LED Solar Street light



Pursuant to the provisions of the WEEE Act, it is forbidden to put waste equipment marked with the symbol of a crossed out bin together with other waste. The user, wishing to get rid of electronic and electrical equipment, is obliged to return it to a waste equipment collection point. There are no hazardous components in the equipment that have a particularly negative impact on the environment and human health.

VIDEX®



90×130°



Ra ≥ 80



ON/OFF

20 000



IK07



50 000 h



Not Dimmable



-20°C +50°C



Free



IP65

WARRANTY 2 YEARS

NEUTRAL WHITE



5000K

Neutral White / Neutralny biały / Neutralni bila / Blanc neuter / Neutrálna biela / Neutraal wit / Semleges feher / Nevtralno bela / Neutrалno bijela / Neutralweiß / Alb neutru / Neutrus balta / Neitrāls balta / Neutraalne valge / Неутрално бяла / Bianco neutro.

This autonomous solar system is designed to illuminate park paths, sidewalks, yards, roads. The set consists of a solar panel, an LED street lamp and a remote controller. The system does not need to be connected to the mains to work, but works by converting sunlight into energy to power the lantern. Energy accumulates in the battery during daylight, after which the lamp can light for up to 12 hours. The lamp is protected from environmental influences such as rain, snow, dirt and mechanical damage.

General parameters

Light source replaceable	no
---------------------------------	----

Type of light source

Dimmable	no
-----------------	----

Technology	LED
-------------------	-----

VIDEX VL-SLSO-605

INDEX: VL-SLSO-605

Electrical parameters

Cable length	1 m
---------------------	-----

Electric shock protection class	III
--	-----

Photometric parameters

Luminous flux	4300 Lm
----------------------	---------

Correlated color temperature	5000K (neutral white)
-------------------------------------	--------------------------

Beam angle	90 × 130°
-------------------	-----------

Color rendering index (CRI)	Ra > 80
------------------------------------	---------

On/Off cycles	20000
----------------------	-------

Lifetime (L70B50)	50000 h
--------------------------	---------

Additional information

Battery power	60 W
----------------------	------

Place of installation	Pillar
------------------------------	--------

Place of application	outdoor
-----------------------------	---------

Impact protection	IK07
--------------------------	------

Housing colour	Gray
-----------------------	------

Diffuser material	Polycarbonate (PC)
--------------------------	--------------------

Minimum distance from the illuminated object	0.5 m
---	-------

Motion sensor	no
----------------------	----

Operating temperature range	-20° +50°C
------------------------------------	------------

Battery voltage	3.2 V
------------------------	-------

Battery capacity	45000 mAh
-------------------------	-----------

Battery type	LiFePO4
---------------------	---------

VIDEX®

VIDEX VL-SLSO-605

INDEX: VL-SLSO-605

Battery replaceable	no
Mercury content	Does not contain
Ingress protection	IP65
Housing material	Aluminum alloy

Dimensions

EAN	4820246481700
In the package	1 pc.
Outer box	1 pcs.
Height	565 mm
Width	189 mm
Depth	95 mm

Signs marking goods

Packaging marking	CE, Utilization
--------------------------	-----------------



VIDEX[®]

VIDEX VL-SLSO-605

INDEX: VL-SLSO-605

VIDEX®

VIDEX VL-SLSO-605

INDEX: VL-SLSO-605



ЛІХТАР

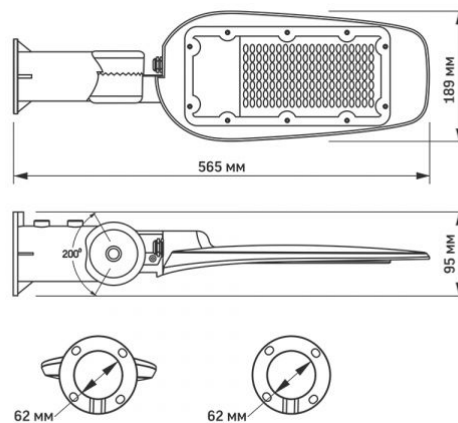

СОНЯЧНА ПАНЕЛЬ

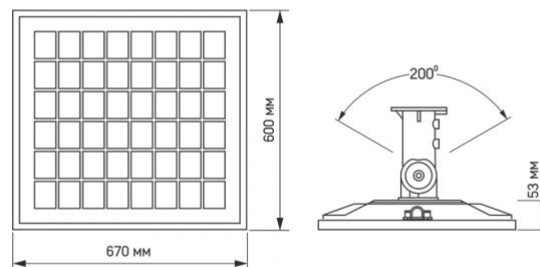

We reserve the right to make technical changes. The data contained in this material is not legally binding.

Allegro opt Sp. z o.o., ul. Mierzeja Wiślana 11,
30-732 Krakow, Poland.



The product must be used outdoors



Class III protection against electric shock - ensured by supplying a specific product with a safe very low voltage (SELV) without the risk of creating a voltage above safe levels



Minimum distance from the illuminated object



The product meets the requirements of EU directives



It is forbidden to throw away waste equipment marked with the symbol of a crossed-out bin with other waste



— Effective light beam angle



— Ra > 80 - color rendering index



— Rated On/off cycles



— The product withstands a medium impact (e.g., from a blunt object)



— Nominal lifetime (hours)



Not Dimmable

— The product is incompatible with light regulators



— Operating temperatures range



— The product does not contain mercury



— Class of protection against dust and moisture.
The product has full protection against dust and water jets from all directions