

System



GW 22 573

TOP SYSTEM - JAZZ BLUE

Code	Description	Configuration	For support codes	Pack Carton
GW 22 571	1 gang		GW24201	24
GW 22 572	2 gang		GW24262	12
GW 22 573	3 gang		GW24201	24
GW 22 574	4 gang		GW24202	12
GW 22 576	6 gang		GW24230	8
GW 22 577	4+4 gang	Overlapping	GW24240	6

CHARACTERISTICS: glossy finish.



GW 22 583

TOP SYSTEM - CORN YELLOW

Code	Description	Configuration	For support codes	Pack Carton
GW 22 581	1 gang		GW24201	24
GW 22 582	2 gang		GW24262	12
GW 22 583	3 gang		GW24201	24
GW 22 584	4 gang		GW24202	12
GW 22 586	6 gang		GW24230	8
GW 22 587	4+4 gang	Overlapping	GW24240	6

CHARACTERISTICS: glossy finish.

PAINTED TECHNOPOLYMER



GW 22 603

TOP SYSTEM - TITANIUM

Code	Description	Configuration	For support codes	Pack Carton
GW 22 601	1 gang		GW24201	12
GW 22 602	2 gang		GW24262	12
GW 22 603	3 gang		GW24201	12
GW 22 604	4 gang		GW24202	12
GW 22 606	6 gang		GW24230	8
GW 22 607	4+4 gang	Overlapping	GW24240	6
GW 22 608	6+6 gang	Overlapping	GW24241	6

CHARACTERISTICS: glossy finish.



GW 22 613

TOP SYSTEM - SLATE

Code	Description	Configuration	For support codes	Pack Carton
GW 22 611	1 gang		GW24201	12
GW 22 612	2 gang		GW24262	12
GW 22 613	3 gang		GW24201	12
GW 22 614	4 gang		GW24202	12
GW 22 616	6 gang		GW24230	8
GW 22 617	4+4 gang	Overlapping	GW24240	6
GW 22 618	6+6 gang	Overlapping	GW24241	6

CHARACTERISTICS: glossy finish.

System



THE RANGE



The System range includes two families of plates and a wide range of devices available in two versions: white components with glossy finish and black components with satin finish. Designed to offer optimum application versatility, the System devices can be flush-mounted or surface-mounted for top practicality and elegance.

SYSTEM SOLUTIONS



The System devices use a wide range of accessories and can be installed in any electrical system: in rectangular flush-mounting and surface-mounting boxes, in boxes for interface with mini trunking, on profiles and DIN rails, in 27 Combi containers

INSTALLATION FLEXIBILITY



The System domestic range is a system offering maximum application flexibility. Versatile, thanks to the dual coupling possibility (on the front or rear of the support) that makes component assembly and release operations easier and quicker.

DOMESTIC RANGES

General characteristics

TECHNICAL DATA AND REFERENCE STANDARDS

Component	Reference standards	Essential electrical data*			Prolonged operation (no. position changes)	Resistance to abnormal heat and fire	
		Resistance at test voltage (V)	Insulation resistance (MΩ)	Breaking capacity or category of use		Thermo-pressure with ball (°C)	Glow Wire Test (°C)
Commands	EN 60669-1	2000 at 50 Hz for 1 minute	> 5	1.25 In (200 position changes)	40,000 at In 250V AC cos φ = 0.6	125	850
Socket-outlets	IEC 60884-1			1.25 In (100 position changes)	10,000 at In 250V AC cos φ = 0.8		
Latching relays	EN 60669-1 / EN 60669-2-2			1.25 In (200 position changes)	50,000 at In 250V AC cos φ = 0.6		
Momentary relays	EN 60669-1 / EN 60669-2-2						
Miniature circuit breakers	EN 60898-1		2** ÷ 5	3KA	8,000		
Residual current circuit breakers	EN 61009-1 / EN 61008-1			3KA	4,000		
Supports and plates	EN 60669-1	-	-	-	-	70	650

* For rated voltages and currents, see the specifications in the single codes.

** The value of 2 MΩ refers to a special condition established by the standards given alongside.

BEHAVIOUR WITH CHEMICAL AND ATMOSPHERIC AGENTS

Component	Agent	Water	Saline solution	Acids		Bases		Solvents			Mineral oil	UV rays	
				Concentrated	Diluted	Concentrated	Diluted	Hexane	Benzol	Acetone			Ethyl alcohol
Plates		Resistant	Resistant	Limited resistance	Resistant	Resistant	Resistant	Limited resistance	Not resistant	Not resistant	Not resistant	Limited resistance	Resistant
SYSTEM devices		Resistant	Limited resistance	Not resistant	Limited resistance	Limited resistance	Resistant	Resistant	Resistant	Resistant	Resistant	Resistant	Resistant

* The resistance values given are valid for an ambient temperature no higher than 40°C.

Terminal resistance to cable traction: > 50N
Device hold on support: > 0.6J

TERMINAL TIGHTENING CAPACITY

Stranded wires		Solid wires	
Minimum	Maximum	Minimum	Maximum
0.75 mm ²	2 x 4 mm ²	0.5 mm ²	2x2.5 mm ²

System

TOP SYSTEM PLATES

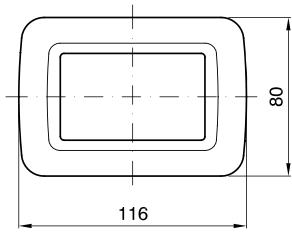

1 GANG - 2 GANG - 3 GANG

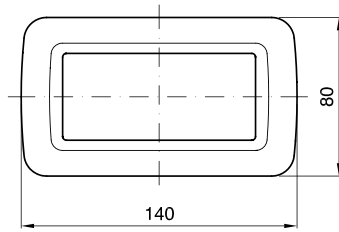

4 GANG

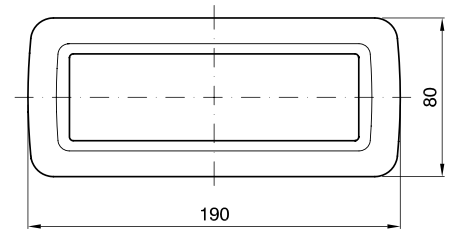

6 GANG

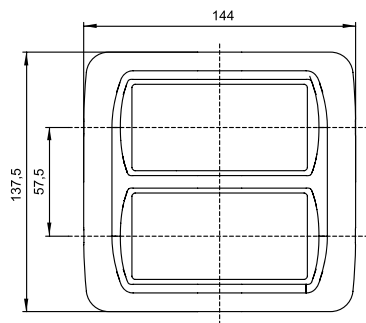

4 + 4 GANG

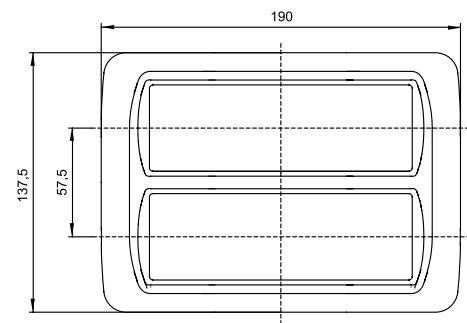

6 + 6 GANG

VIRNA PLATES

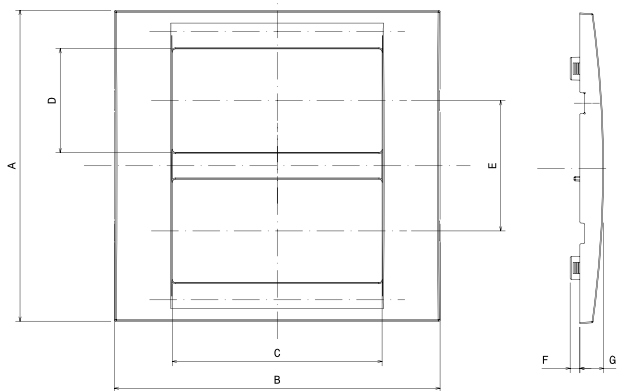
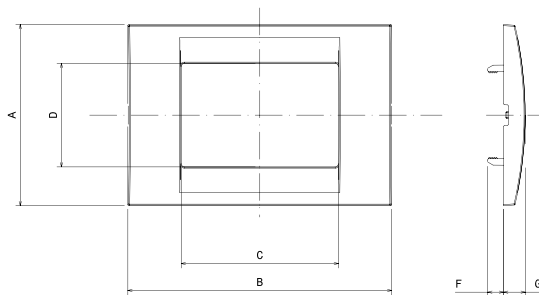

	A	B	C	D	E	F	G
1 GANG	80	116.5	23	45.7		7	9.5
2 GANG	80	116.5	46.4	45.7			9.5
3 GANG	80	116.5	69.4	45.7		7	9.5
4 GANG	80	139.6	92.6	45.7		7	9.5
6 GANG	80	190	138.8	45.7		4.3	9.5
(4+4) 8 GANG	137.2	143.8	92.6	45.7	57.5	4.3	10.5
(6+6) 12 GANG	137.2	190	138.8	45.7	57.5	4.3	10.5

COMPACT PLATES

1 GANG - 2 GANG - 3 GANG - 4 GANG

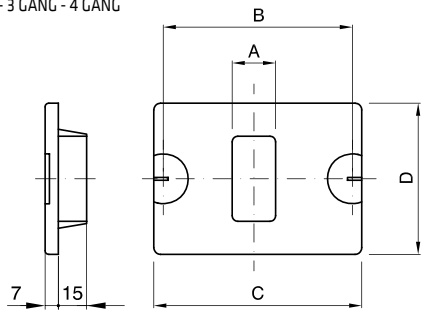

3 + 3 GANG

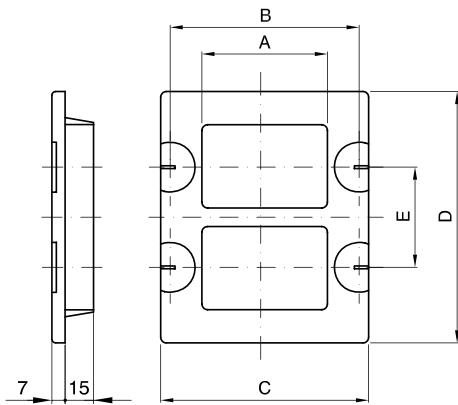

Compact					
Code	GW 24 001	GW 24 002	GW 24 003	GW 24 004	GW 24 005
A	1 GANG	2 GANG	3 GANG	4 GANG	3 + 3 GANG
B	83.5	83.5	83.5	108.5	83.5
C	110	110	110	134	110
D	80	80	80	80	133
E	-	-	-	-	51