

DATA SOCKETS



GW 20 686

RJ45 SOCKETS

Code	Description	No. pairs	Use category	Cables	Connection	No. SYSTEM modules	Pack Carton
GW 20 271	RJ45	4	5e	UTP	Toolless	1	15/30
GW 20 243	RJ45	4	5e	FTP	Toolless	1	15/30
GW 20 685	RJ45	4	6	UTP	Toolless	1	15/30
GW 20 684	RJ45	4	6	UTP	Toolless	1	1/15
GW 20 686	RJ45	4	6	FTP	Toolless	1	15/30

APPLICATIONS: LANs up to 100MHz (e.g. Ethernet, Token Ring networks) for cat. 5e. LANs up to 250MHz (e.g. Videoconference systems, CCTV) for cat. 6.



GW 20 266

ADAPTERS FOR HOUSING DATA CONNECTORS

Code	Compatibility	No. SYSTEM modules	Pack Carton
GW 20 266	IBM	1	1/120
GW 20 267	SYSTIMAX COMMSCOPE	1	1/120
GW 20 270	AMP / Keystone Jack	1	1/120

NOTES: with regard to the technological developments and dimensional variants introduced by connector manufacturers, you are advised to check in advance the full compatibility between the connector and the Gewiss adapter.

USB AND HDMI COUPLERS



GW 38 056

USB AND HDMI COUPLERS

Code	Description	Type	Compatibility	Pack Carton
GW 38 056	HDMI coupler	Female/Female	Keystone Jack	1/48
GW 38 057	USB coupler	Female/Female - A type	Keystone Jack	1/48

NOTES: for adapters (Chorus, System, Playbus and Dahlia) with Keystone Jack coupling and for patch-panels.

USB POWER SUPPLY



GW 20 361

DOUBLE USB POWER SUPPLY FOR ELECTRONIC DEVICES

Code	Supply voltage	Output voltage	Max current supplied	No. Chorus modules	Pack Carton
GW 20 361	100/240 V ac - 50/60 Hz	5V dc	2,1 A	1	1/10

CHARACTERISTICS: equipped with two USB, A-type, female connectors that supply a total of 2.1A.

APPLICATIONS: suitable to recharge a single 2.1A electronic device (e.g.: tablet) or a couple of simultaneous devices (e.g.: tablet and smartphone). The total current provided (max. 2.1A) is split in the two USB outputs, depending on the state of charge of the connected devices.

ONE PLATES

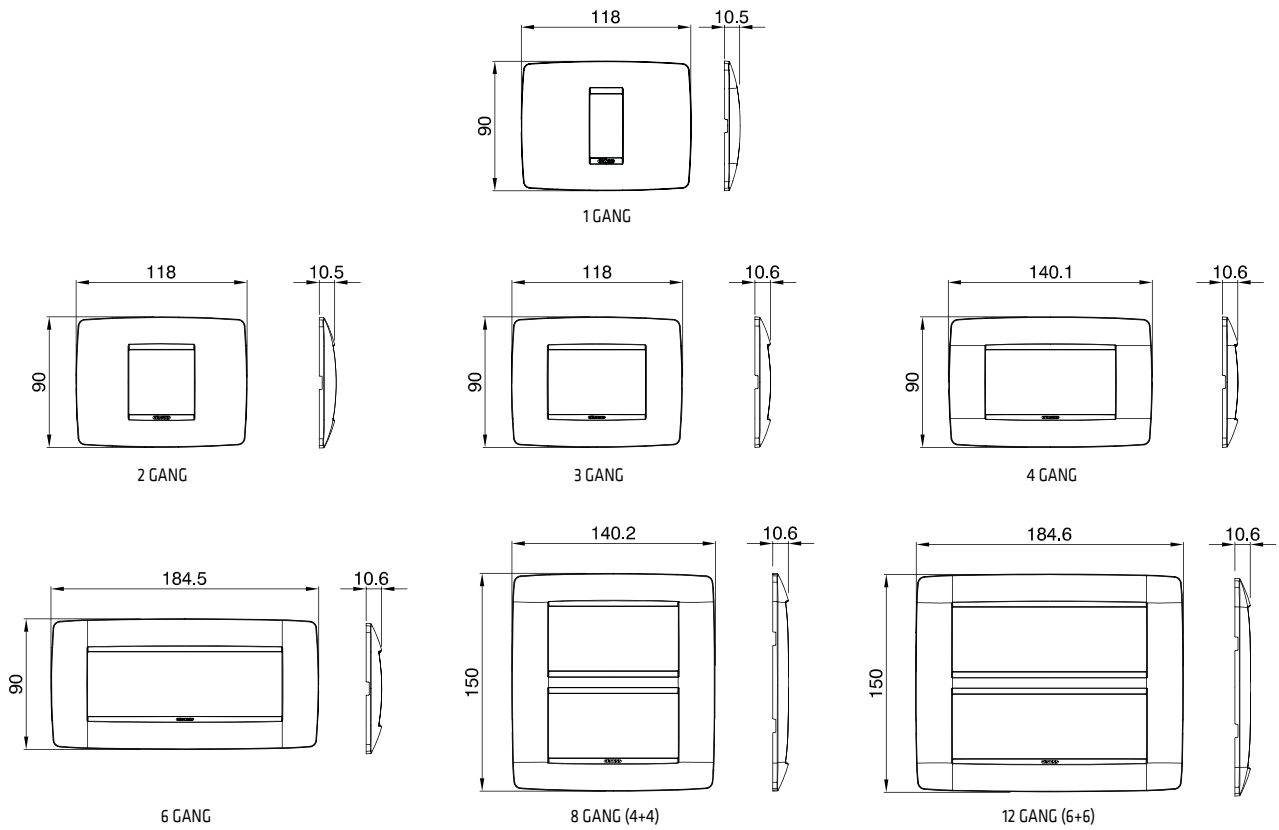

ONE INTERNATIONAL PLATES

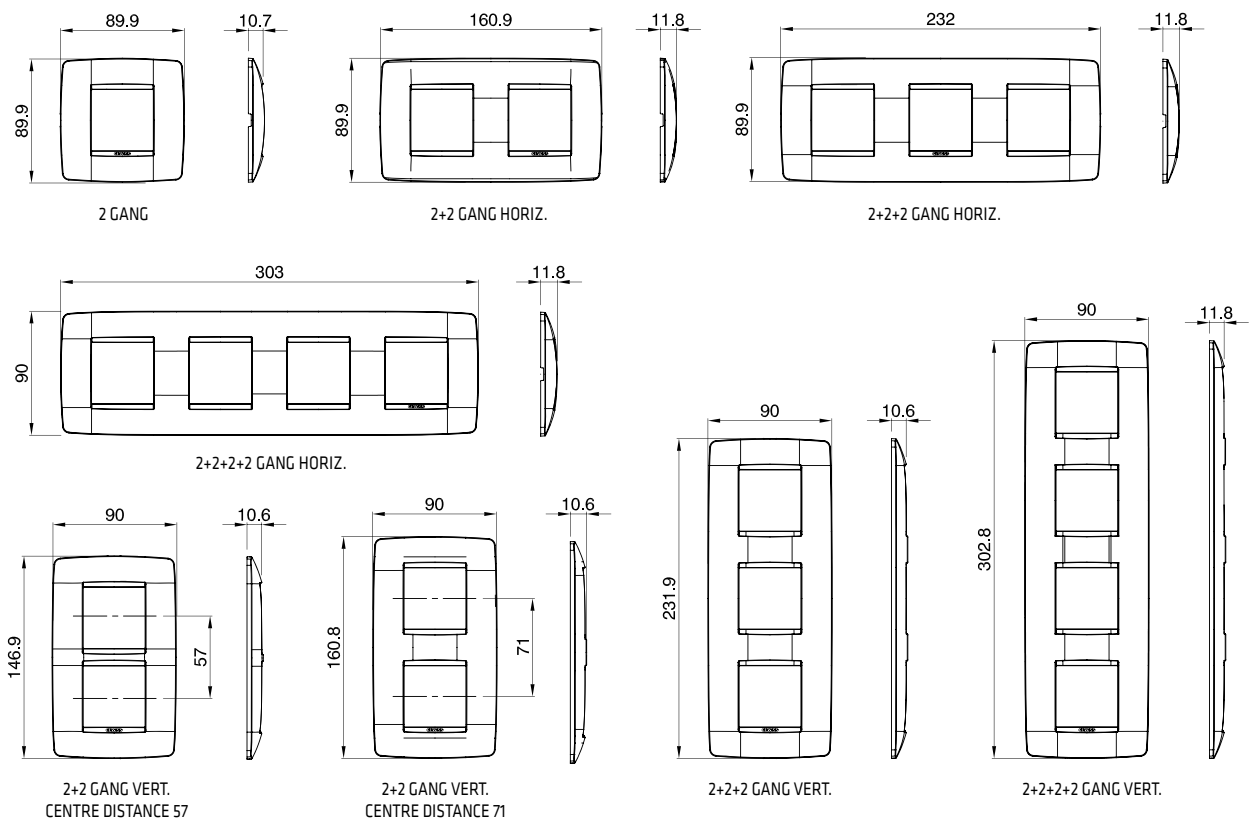

GEO PLATES

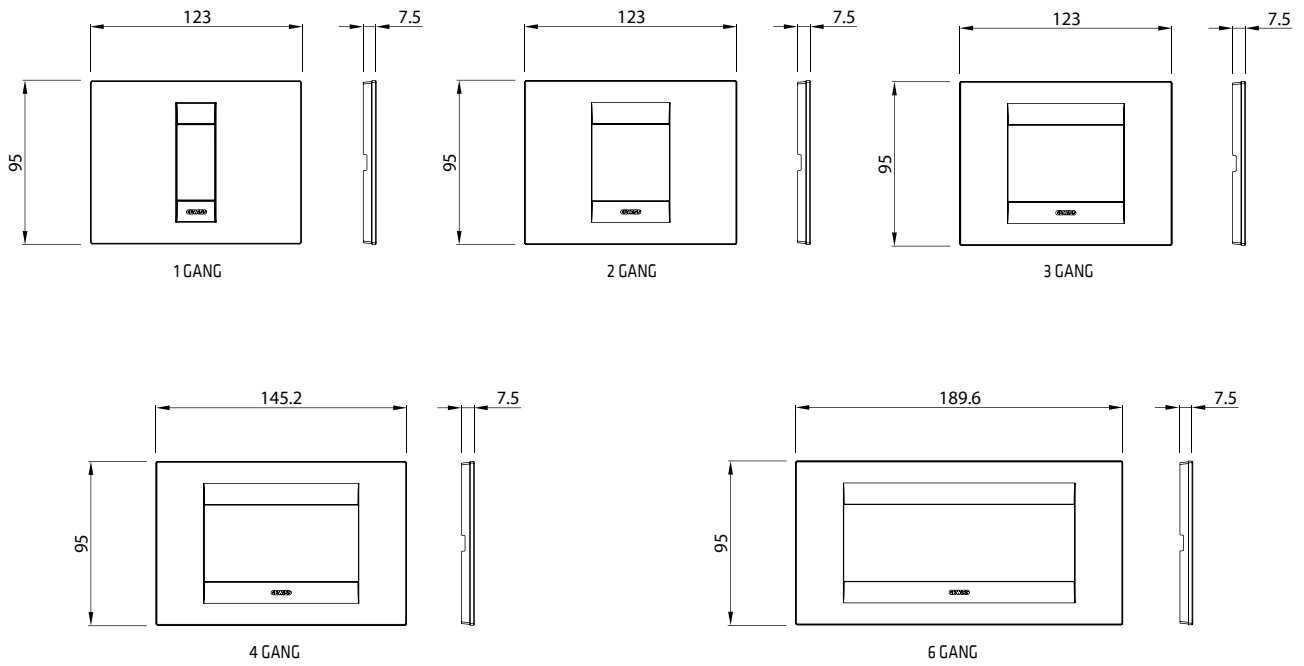

GEO INTERNATIONAL PLATES

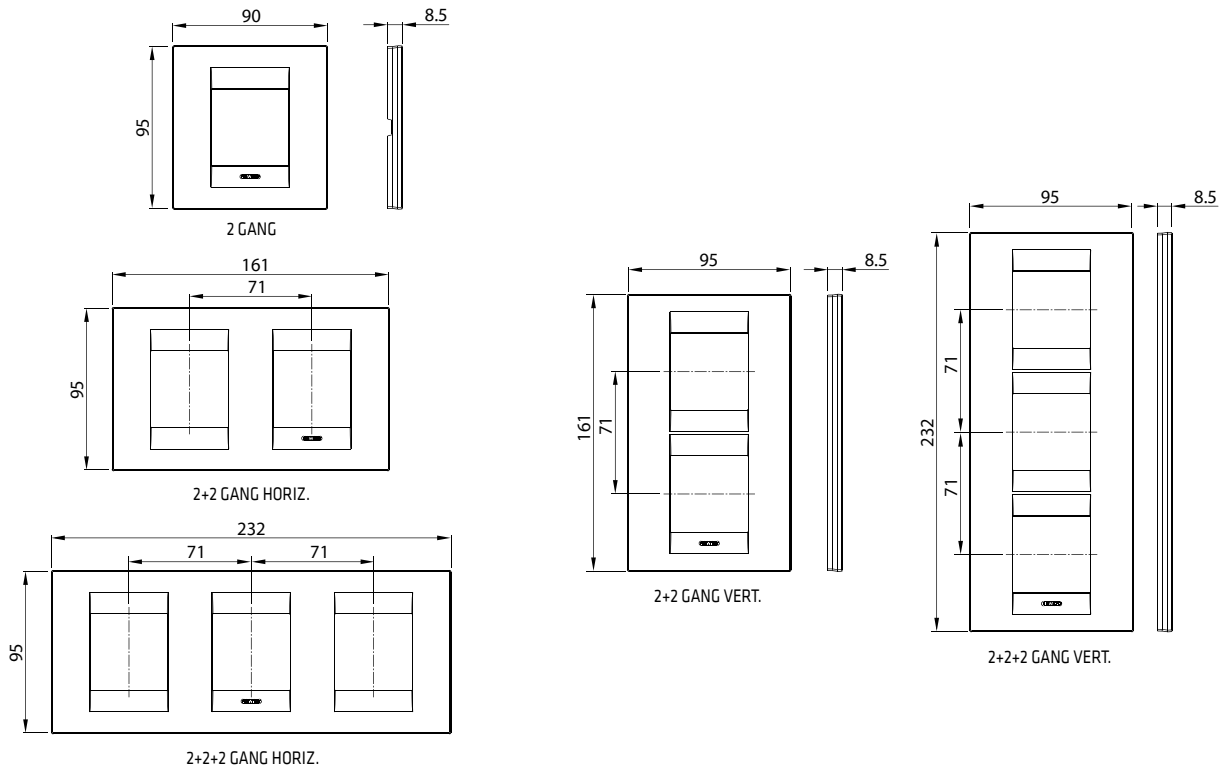

LUX PLATES

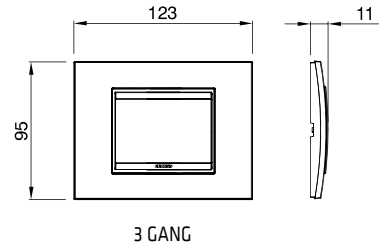
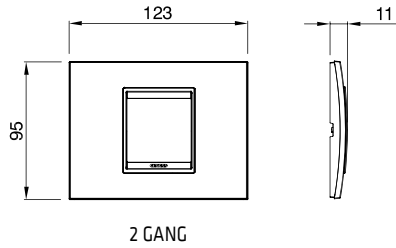

DOMESTIC RANGES

LUX INTERNATIONAL PLATES

