

# FA-3X...

## KEY FUNCTIONS

- \* The design of the inverter is based on a powerful 32-bit DSP processor for fast and effective implementation of advanced control algorithms for asynchronous three-phase motor.
- \* Option to work in speed control mode or driving torque control mode.
- \* Motor control based on the sensorless vector control and control by freely programmable V/F characteristic.
- \* Automatic slip compensation and a large starting driving torque (even up to 180% at a frequency of 0.5 Hz).
- \* PLC mode – option to program up to sixteen steps carried out once or periodically by the inverter.  
For each of the steps, you can determine the speed, acceleration time and duration.
- \* High programming freedom for inverter inputs and outputs, both analog and digital.



## TYPY

Inverter type	Input voltage V	Input current A	Output voltage V	Output current A	Motor power max kW	Length L mm	Width W mm	Height H mm
FA-3X110	3×400V	26A	3×400V	25A	11kW	360	220	210
FA-3X150	3×400V	35A	3×400V	32A	15kW	360	220	210
FA-3X220	3×400V	47A	3×400V	45A	22kW	435	225	242

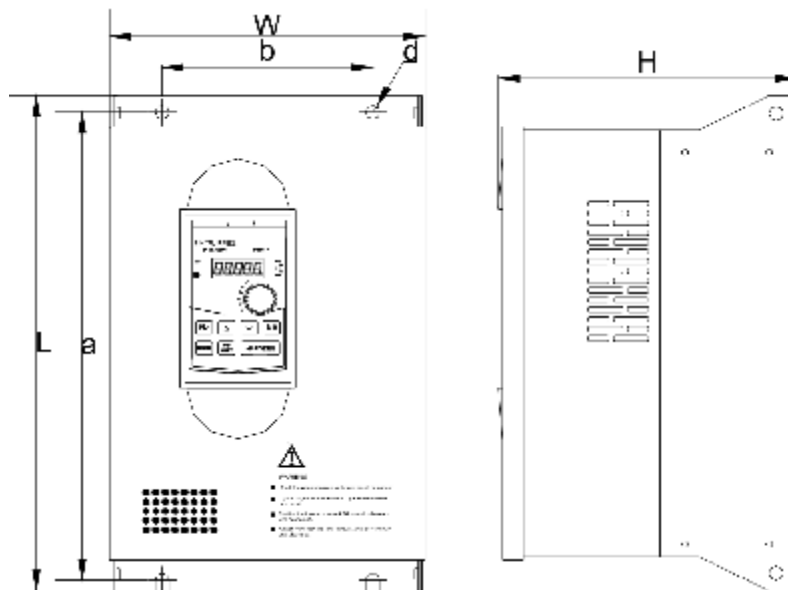

CONTROL PANEL

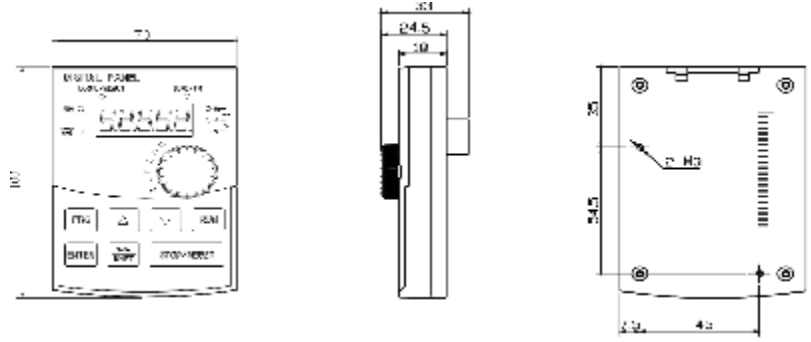

Control panel is detachable from the main body of the inverter.  
 This allows for external mounting on the cabinet door for quick access to settings and adjust the parameters of the inverter.

IN/OUT DESCRIPTION

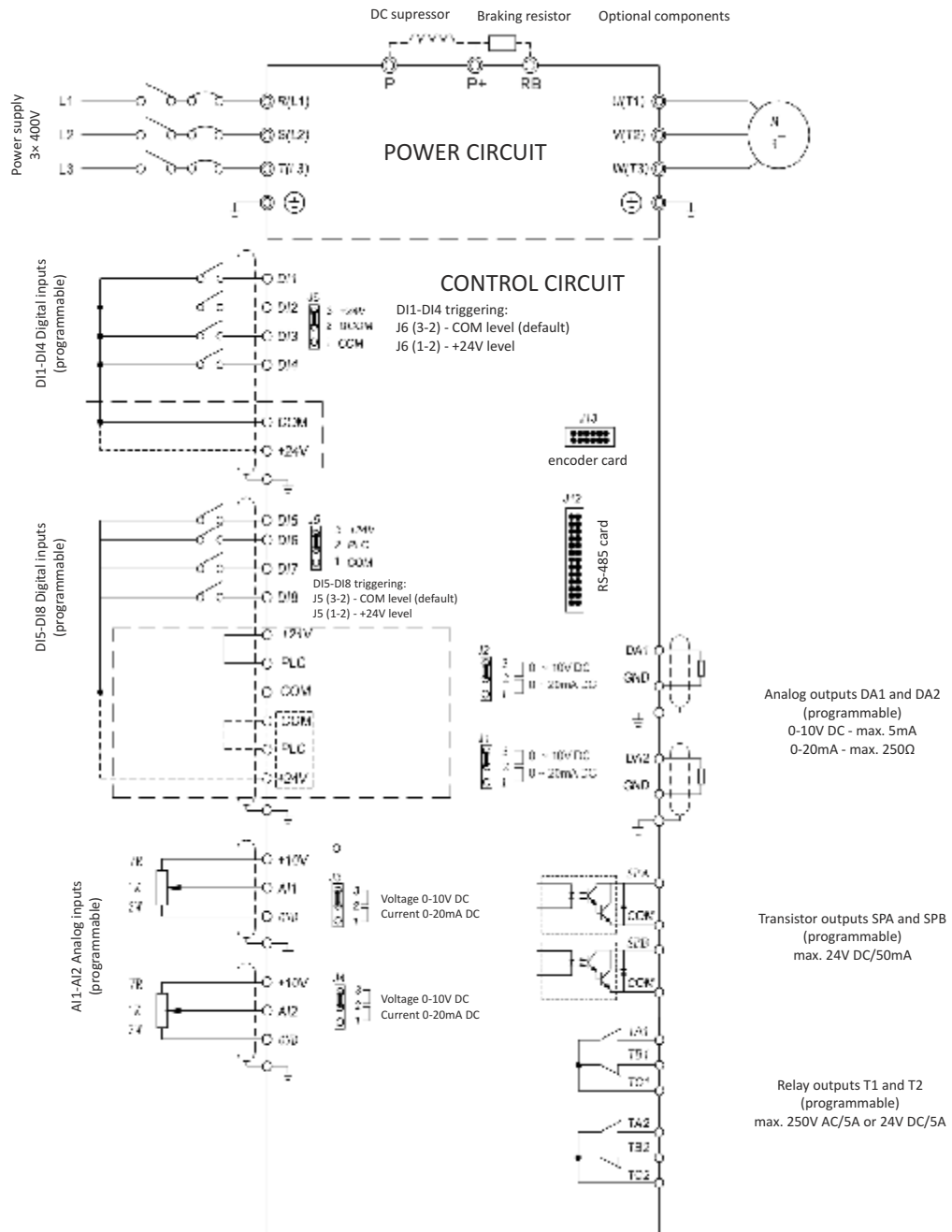

## SPECIFICATIONS

Function		Technical data
Power supply	Voltage and frequency	3× 380÷415V (±10%), 50/60Hz (±5%)
	Output voltage	3× 380÷400V (for zasilania 400V)
	Output frequency	0.00÷3200 Hz (U/f control) 0.00÷300 Hz (vector control)
	V/F control characteristic	1) Constant torque characteristics 2) Reduced torque characteristics 3) Torque characteristics set by the user 4) Vector control (sensor and sensorless)
	Starting torque	180% for 0.50 Hz
	Speed control dynamics	1: 100
	Output speed stability	±0.5%
	Torque boost	In V/F control mode – automatic or defined by the user
	Acceleration/deceleration	Linear characteristic or in accordance to program curve S. Maximum acceleration and deceleration: 6500 sec
	Accuracy frequency reference	Digital frequency reference: 0,01Hz (f≤100Hz), 0,1Hz (>100Hz); Analog frequency reference: 1% of maximum frequency
	Overload	1) 150% rating current for 1 minute 2) 200% rating current for 0.1 sec
	Motor slip compensation	In V/F control mode, motor slip can be compensated automatically
Protection	Inverter protection	1) Against too high and too low power voltage 2) Against exceeding the maximum current 3) Against too high load 4) Against the loss of speed and motor stall 5) Against current outflow to ground 6) Against inverter overheating 7) Inverter is additionally protected against communication errors and incorrect feedback signal
	Safety switch	Input or button can be programmed as a safety switch that will immediately cut off the voltage from the outputs of the inverter
	Settings protection	Inverter settings can be protected with PIN number
	Error deleting	Errors can be cleared both manually and automatically
Braking	Deceleration using DC and the external braking resistor	
IO	8 digital inputs	1) Inputs activation with both low (COM) and high level (+24 V) 2) High programming freedom of various functions: forward and backward gear, trial forward and backward gear, safety switch, reset, multi-speed control, motopotentiometer, acceleration and deceleration time change, pulse input and other
	3 analog inputs	1) They can work both as input voltage (0÷10 V) and current inputs (0÷20 mA) (4÷20 mA range can also be programmed) 2) Analog inputs can be used for, among other things, frequency and torque setting and working with PID regulator.
	2 analog outputs	1) They can work both as input voltage (0÷10 V) and current inputs (0÷20 mA) 2) Analog outputs can be programmed to indicate: <ol style="list-style-type: none"> <li>preset and current frequency</li> <li>output voltage</li> <li>voltage on DC bus</li> <li>temperature of IGBT terminal power</li> <li>output power</li> <li>motor rotational speed</li> <li>torque</li> </ol>

	2 transistor outputs	<p>1) Fast pulse outputs (max frequency: 100 kHz). Indications:</p> <ul style="list-style-type: none"> <li>a. preset frequency</li> <li>b. current frequency</li> <li>c. electric current value</li> <li>d. output voltage</li> <li>e. voltage on DC bus</li> <li>f. temperature of terminal power</li> <li>g. output power</li> <li>h. motor rotational speed</li> <li>i. torque</li> </ul> <p>2) Transistor load - max 20 mA/27 V</p>
	1 relay output	<p>1) Contact load 5 A/250 V AC or 5 A/30 V DC</p> <p>2) High freedom of output functions programming (indication of 34 different inverter states)</p>
Speed adjustment		<p>1) Wide range of speed settings, including combinations of digital inputs, analog inputs, potentiometer and keys on control panel, pulse inputs and motopotentiometer</p> <p>2) Multi-speed - user can set 16 different speeds and eight times of acceleration/deceleration</p> <p>3) PLC mode - user can define sequences of up to eight steps that will be automatically executed by the inverter. For each step user can define motor speed, acceleration/deceleration time and the duration of the step, as well as whether the sequence is to be executed once or in a loop.</p>
PID		<p>Built-in PID regulator increases the ability to match the drive operation to the requirements of the technological process. Preset value and feedback signal can be entered from one of the following sources:</p> <ul style="list-style-type: none"> <li>1) Control panel (keys or potentiometer)</li> <li>2) Analog inputs</li> <li>3) Digital inputs</li> <li>4) Pulse input</li> </ul>
Environmental conditions	Working temperature	-10°C ÷ 40°C. If the temperature exceeds 40°C, then maximum output current is reduced by 1% with each additional °C
	Storage	-20÷65°C
	Humidity	Below 90%, without humidity condensation
	Height	0÷1000 m
	Assembly	Installation in a vertical position inside the control cabinet with good ventilation and on the mounting plate made of non-combustible material. Mounting method must also protect the inverter from direct sunlight, dust, humidity and corrosive or explosive gases.
	Ventilation	Cooling by natural and forced air flow