

SR EN 60947-3



MGN15707



MGN15712









MGN15714

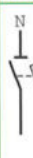

MGN15718

- Separatoarele cu fuzibili SBI asigură protecția la suprasarcină și la scurtcircuit.
  - Se folosesc în aplicații industriale unde este necesară o capacitate de rupere mare.
  - Asigură funcția de secționare și nu trebuie utilizate ca separatoare.
  - Sunt echipate cu indicator luminos pentru semnalizarea arderii fuzibilului: se vor echipa cu fuzibili tip aM sau gG (gL-gl) fără percutor.
- Fuzibilii pentru utilizare generală (**fuzibili gG**) asigură protecția la suprasarcină și la scurtcircuit.
- Fuzibilii pentru protecția motoarelor (**fuzibili aM**) asigură doar protecția la scurtcircuit. Se folosesc pentru protecția sarcinilor cu vârfuri mari de curent (motoare, primarul transformatoarelor, etc.).

## Referințe

Fuzibili							Separatoare cu fuzibili SBI					
Tip	Calibru	Tensiune nominală (Ue)	Curent de scurtcircuit (Isc)				Tip rețea					
			aM	gG	aM	gG	N	1P	1P+N <sup>(1)</sup>	2P	3P	3P+N <sup>(1)</sup>
												
14 x 51 mm	10 A	690 V CA	120 kA	120 kA	DF2EA10	DF2EN10	MGN15708	MGN15707	MGN15709	MGN15710	MGN15711	MGN15712
	12 A	690 V CA	120 kA	-	DF2EA12	-						
	16 A	690 V CA	120 kA	120 kA	DF2EA16	DF2EN16						
	20 A	690 V CA	120 kA	120 kA	DF2EA20	DF2EN20	3 pași de 9 mm	3 pași de 9 mm	6 pași de 9 mm	6 pași de 9 mm	9 pași de 9 mm	12 pași de 9 mm
	25 A	690 V CA	120 kA	120 kA	DF2EA25	DF2EN25						
	32 A	500 V CA	120 kA	120 kA	DF2EA32	DF2EN32						
	40 A	500 V CA	120 kA	120 kA	DF2EA40	DF2EN40						
	50 A	400 V CA	120 kA	120 kA	DF2EA50	DF2EN50						
22 x 58 mm	32 A	690 V CA	80 kA	80 kA	DF2FA32	DF2FN32	MGN15714	MGN15713	MGN15715	MGN15716	MGN15717	MGN15718
	40 A	690 V CA	80 kA	80 kA	DF2FA40	DF2FN40						
	50 A	690 V CA	80 kA	80 kA	DF2FA50	DF2FN50	4 pași de 9 mm	4 pași de 9 mm	8 pași de 9 mm	8 pași de 9 mm	12 pași de 9 mm	16 pași de 9 mm
	63 A	690 V CA	80 kA	80 kA	DF2FA63	DF2FN63						
	80 A	690 V CA	80 kA	80 kA	DF2FA80	DF2FN80						
	100 A	400 V CA	120 kA	120 kA	DF2FA100	DF2FN100						
	125 A	400 V CA	120 kA	-	DF2FA125	-						

Frecvența de lucru: 50/60 Hz

(1) Polul neutru vine echipat cu un cartuș cale de curent.

# Separatoare cu fuzibili SBI cu indicator luminos

## Dimensiuni (mm)

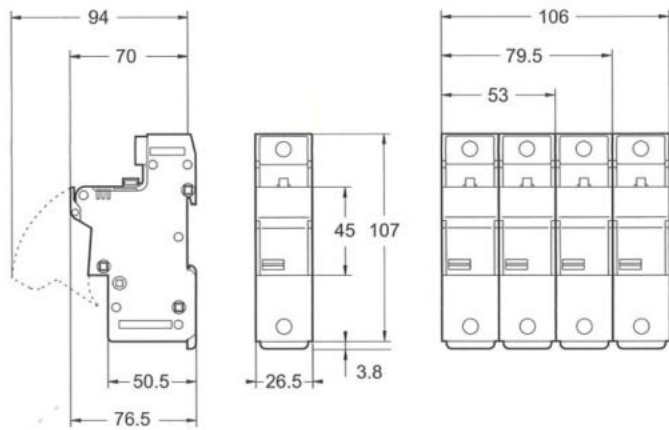

14 x 51 mm

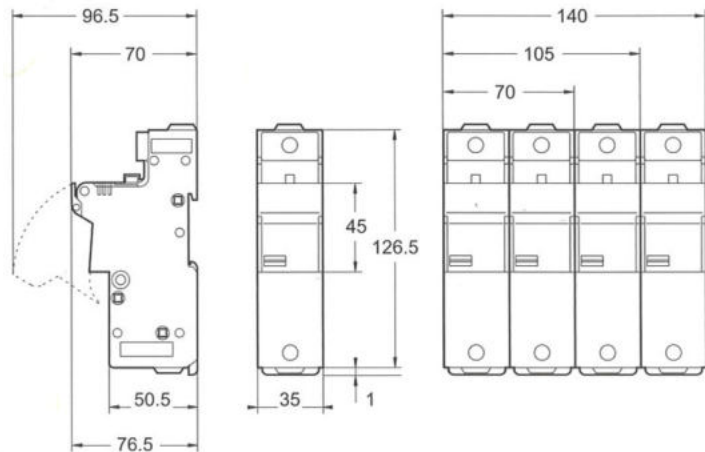

22 x 58 mm

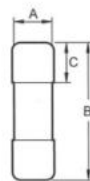

aM, gG

Fuzibili aM, gG			
Tip	A	B	C
14 x 51 mm	14.3	51	13.8
22 x 58 mm	22.2	58	16.2

*a x b x c*