

Built for a lifetime.

astreea®

ENG

# Installation Guide

## EV Charger – All Vertical Models

ACS111, ACS121, ACS211 and ACS221  
(11KW/22KW) and subsets.

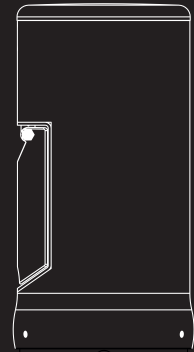
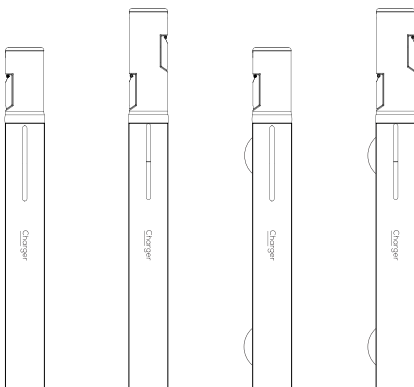

Charger



Scan for:  
Official Website



### **Before you start:**

1. We recommend **qualified personnel** for this operation
2. Time needed: **up to 1 hour**
3. **Retain this Guide** for future reference
4. These **cards** that you will find in the Guide are very important. Please give them your **attention**.

Astreea Igloos North America, LLC PO Box 773192  
Eagle River Alaska 99577 [www.us.astreea.com](http://www.us.astreea.com)

Please call our customer service  
US & Canada: (907) 931-4469 (English and French)  
or contact email address at: [info@us.astreea.com](mailto:info@us.astreea.com)  
CUSTOMER SERVICE HOURS ARE: 9.00 AM - 4.00 PM MONDAY - FRIDAY EST.

# Summary

## Installation guide for self standing chargers

---

<b>1. Requirements before installation</b>	<b>04</b>
<b>2. About our EV chargers and technical data</b>	<b>10</b>
<b>3. Assembly. Anchoring with foundation and metal frame.</b>	<b>14</b>
<b>4. Linking the wires</b>	<b>15</b>
<b>5. Finishing the installation</b>	<b>18</b>

---

## Installation guide for wall chargers

<b>1. Anchoring the charger to the wall</b>	<b>21</b>
<b>2. Linking the supply line and wires</b>	<b>26</b>
<b>3. Finishing the installation</b>	<b>27</b>

---

## Usage operations

<b>1. LED status indicator</b>	<b>29</b>
<b>2. Astreea® Charger App</b>	<b>30</b>

# 1. Requirements before installation

astrøea®



**If any malfunctions or issues arise as a result of an incorrect installation, please initially reach out to the company responsible for the installation.**

**If the problem persists, don't hesitate to get in touch with Astreea® Support.**

[info@astreea.com](mailto:info@astreea.com)

[astreea.com/charger](http://astreea.com/charger)

## 1.1 Safety instructions

Please review the safety guidelines provided below prior to utilizing the EV Charging Station to minimize the potential dangers of fire, electrical shocks, personal harm, or equipment damage. Only trained personnel should perform installations and adjustments. To mitigate the risk of electrical shock, refrain from conducting any maintenance unless you possess the necessary qualifications, as outlined in the operating instructions.

When working with electrical components, adhere to the local and national wiring standards and regulations, as well as the instructions provided here for installation. Connecting to the main power supply must align with the national regulations governing electrical installations.

This product has been meticulously designed and tested to comply with international standards. Utilize the equipment solely for its intended purpose and within the specified operating parameters.

## 1.2 Liability

**Astreea® assumes no liability** for the following cases in the event of personal injury or property damage:

- **Mishandling of the charging station**
- **Structural modifications to the charging station**
- **Deployment of unqualified technical personnel for installation**
- **Utilization of unauthorized spare parts or accessories**
- **Alterations to the configuration of the charge controller**
- **Inappropriate usage of the charging station**
- **Failure to adhere to the instructions provided in the manual**

## 1.3 Intended use

The charging station is designed exclusively for charging electric vehicles, such as electric cars, and should not be used to connect other devices like power tools.

This charging station is suitable for both indoor and outdoor use and must be installed vertically on a wall or a stable floor foundation with a flat surface, such as a brick or concrete wall. The installation and connection of the charging station must comply with the relevant national regulations.

The intended use of this device always includes compliance with the environmental conditions for which it was specifically developed.

The charging station has undergone development, manufacturing, testing, and documentation processes in accordance with the appropriate safety standards.

It's important to note that as long as the provided instructions and safety guidelines for the intended use are followed, the product is unlikely to pose any health risks to individuals or cause damage to property.

However, it is crucial to emphasize that failure to adhere to these safety instructions can result in severe risks, including the possibility of fatalities, injuries, and damage to the device.

**It is of utmost importance to exercise extreme caution in adhering to the warnings outlined in this installation and operating manual. Below, we provide explanations for the significance of each individual symbol:**



**Danger! Electrical voltage hazard**  
Ignoring the instructions may result in damage to the charging station, serious injury or even death.



**Attention! General safety hazard**  
Ignoring the instructions may result in damage to the charging station, serious injury or even death.



**Advice/Note! Important information or procedure**  
Said instructions must be followed for the orderly operation of the charging station.

## 1.4 Requirements and Observations

### The following requirements and observations must be met and followed:



- No direct spray of water on the surface of the charger.
- Have enough distance present from other technical equipment.
- No installation in areas with high risk of flooding.
- No installation in areas with any risk of explosion.
- Make sure the charging cable is not being strained during the charging operation or obstructed by any direct or indirect means.
- The mounting surface must be designed with sufficient strength in order to withstand the mechanical stress specified in the Guide (concrete is recommended).
- The ambient temperature must not be lower than -20 °C or higher than 50 °C.
- For installation of low-voltage systems, the specifications IEC 60364-1 and IEC 60364-5-52 must comply.
- Make sure the power supply assigned to the charger has sufficient capacity to uphold the electrical consumption of the charger.
- Ensure the electrical protection of the power supply assigned to the charger before, during and after the charging procedure.
- A stable and high-performing wireless internet connection is required for receiving software updates and the proper operation of the charger and mobile application.
- The housing of the charging system must always be kept closed.
- When the charging system is connected, you must not clean or wash the vehicle with a high-pressure cleaner because the plug-in connection is not sealed against direct pressurized water.
- Never install near fire sources, explosive materials, combustibles or other flammable sources.
- Never use it at places where gas or other chemical explosions could occur.
- It must be connected all the times to the ground, otherwise it will not allow charging.
- Turn off the EV Charging Station power before installing or performing operations to it.
- Make sure children are supervised if using the equipment.
- Do not put fingers or insert objects or sharp metallic objects into the terminals. Do not insert objects into any other parts of the EV Charging Station.
- Do not use the device if the power cord or EV cable is broken, shows any signs of damage or does not function properly.
- Do not use the Charging Station if it is broken, defective, cracked, damaged or does not function properly.
- Do not apply strong force on the equipment, to prevent crashes and deterioration.
- Do not use any sharp objects to damage the product.
- Do not service the equipment by yourself, do not open, disassemble or make any modifications to it.
- Do not touch any live electrical parts.
- Do not place the charging cables connected to the charging station in water.
- Make sure ground connection is properly done to prevent equipment damage.
- Transport the device with care in its original package to avoid damage to it and its components.
- As the Charging Station can affect the functioning of certain medical electronic implants, check any potential side effects with your electronic device manufacturer before using the device.

The charging system is not suitable for charging vehicles with outgassing batteries (e.g. leadacid batteries).

**The charging protocol respects the following IECs:**

- **Charging in accordance with type 3 of IEC 61851-1**
- **Socket connectors in accordance with IEC 62196-2**

The charging system is solely designed for fixed installations and should only be operated and utilized by individuals who have thoroughly reviewed the operating manual.

Qualified electricians are required to have thoroughly studied and comprehended the equipment documentation and are expected to adhere to its instructions.

## 1.5 Qualification of electricians

**The electrician entrusted with the installation should possess expertise in the following areas:**

- **Up-to-date safety guidelines**
- **Safety instructions detailed in the manual**
- **Proficiency in both fundamental and advanced electrical and electronic skills**
- **Familiarity with safety procedures concerning electrical system operation**
- **Experience in the installation of three-phase electrical systems**
- **Knowledge of circuit breaker voltages and fundamental principles**



**When deciding on the placement of your Astreea® Charger, please keep in mind the importance of not obstructing entry or exit points and allowing for the passage of rescue or emergency vehicles.**

**Additionally, make an effort to steer clear of locations where other individuals might stumble upon or accidentally collide with the station.**

## 1.6 Pacemakers or ICDs

Guidance for Individuals with Pacemakers (PM) or Implantable Cardioverter Defibrillators (ICD):

Astreea® charging systems, when used as intended, comply with the European guideline on electromagnetic compatibility, specifically regarding radiated interference.

If individuals with pacemakers (PM) or implantable cardioverter defibrillators (ICD) wish to engage in activities involving charging systems and their associated devices as per their intended usage, Astreea® cannot provide any assessment regarding the suitability of these medical devices. Astreea® lacks the capability to evaluate

the susceptibility of pacemakers or implantable cardioverter defibrillators to electromagnetic radiation. Only the manufacturers of these medical devices can provide such assessments.

As a precaution, Astreea® recommends that individuals in this category consult with the manufacturer of their pacemaker or defibrillator, as well as their relevant insurance company, before working on Astreea® charging systems.

This step is essential to ensure that no potential health or safety risks are involved in their use.

## 1.7 Installation and tests

**Guidelines for Choosing Protective Equipment for Basic and Fault Protection Against Direct or Indirect Contact:**

- **Electrical Circuit Breakers:** It is essential to safeguard the charging system using circuit breakers that adhere to the specific regulations established by the relevant national authorities.

The selection of these circuit breakers depends on factors such as the required tripping time, internal network resistance, conductor cross-sectional area, conductor lengths, and the preset rating of the charging system.

The short-circuit protection mechanism of the conductor should possess a characteristic that allows for 8-10 times the  $I_{nom}$

value (nominal current) and must not surpass a maximum nominal current of 32 A, contingent upon the preset rating of the charging system.

- **Residual-Current Circuit Breaker (RCD):** To ensure personal safety, it is possible that national regulations require an upstream RCD with a sensitivity of 30 mA AC. Select an appropriate RCD that aligns with the national regulatory requirements.

- **AC Residual-Current Detection:** The charging system comes equipped with built-in AC residual-current detection as a convenient feature. This detection mechanism will deactivate the charging system, at the latest, when a residual current exceeding 30 mA AC is detected.

## 1.8 Information on initial inspections after installation and repeat inspections

National regulations may necessitate inspections of the charging system both before its initial startup and at regular intervals thereafter. These inspections should be conducted in strict accordance with the relevant rules and regulations.

**Below, we provide guidance on how to carry out these inspections:**

**1. PE Conductor Test:** After the installation and before the first activation, it is essential to assess the continuity of the PE (Protective Earth) conductor. To perform this test, connect the charging coupler to a test adapter designed for vehicle simulation as per EN 61581-1 guidelines. Measure the resistance of the PE conductor between the PE conductor socket of the adapter and the connection point of the PE conductor within the building's electrical cabinet.

The resistance of the PE conductor, for a total conductor length (including the connecting line to the charging system and the vehicle charging cable) of up to 5 meters, should not exceed 300 milliohms (mΩ).

For longer cables, you may need to adjust the value in accordance with applicable national regulations. In any case, the resistance must not exceed 1 ohm.

**2. Insulation Test:** Since the charging system incorporates a disconnecting relay, two insulation measurements are required. To conduct these tests, the charging system must be disconnected from the power supply. Therefore, before performing the measurement, ensure that the supply voltage is switched off using the circuit breaker located in the building's electrical cabinet.



**Ensure that the power supply line feeding into and around the charger is disconnected during the foundation creation, installation, or repair process.**

**Neglecting to follow these safety instructions can pose a potentially lethal risk associated with electric voltage.**

## 1.9 Working on the charging system without risk

Prior to connecting the charger to the vehicle, please adhere to the following precautions:

- Ensure that the connecting line of the charging system is fully unwound.
- Thoroughly inspect the charging system's housing, connecting line, charging coupler, cable, and connectors to confirm that they are free from any damage.
- When handling the plug-in connection of the charging system, hold onto the charging coupler rather than the charging cable.

- Take precautions to prevent anyone from potentially tripping over the charging cable.

In the event of malfunctions or a failure of the charging system:

- Disconnect the charging system from the power supply by turning off the corresponding circuit breaker located within the building.
- Display a notice indicating the name of the authorized individual responsible for reactivating the circuit breaker.

## 1.10 Measurements and tests

### Primary Side Insulation Measurement:

Conduct an insulation resistance measurement on the primary side of the charging system at the point where the power supply line connects to the charging system within the building's electrical cabinet. The recorded value should not surpass 1 megaohm (MΩ).

### Secondary Side Insulation Measurement:

To perform this measurement, connect the charging coupler to a test adapter designed for vehicle simulation following the EN 61581-1 standards. Measure the insulation through the measuring sockets located on the test adapter. Ensure that the measured value does not exceed 1 megaohm (MΩ).

Alternatively, you can utilize the differential current method in conjunction with the measurement of the Protective Earth (PE) conductor current. In both scenarios, the recorded value must not exceed 3.5 milliamperes (mA).

To conduct these measurements, connect the charging coupler to a test adapter designed for vehicle simulation per the EN 61581-1 guidelines. Perform the measurements with the adapter set to the "C mode" and gauge the differential current at the point where the power supply line connects to the charging system within the building's electrical cabinet.

## 1.11 Testing

### Testing Power-Off Condition in the Event of a Short-Circuit:

For these assessments, connect the charging coupler to a test adapter designed for vehicle simulation following EN 61581-1 standards. These measurements should be conducted with the adapter set in the "C mode."

Perform the measurements using the measuring sockets on the test adapter. Ensure that the recorded values align with those specified for the chosen circuit breaker.

### • Testing Power-Off Condition in Case of a Fault:

For these evaluations, link the charging coupler to a test adapter designed for vehicle simulation in accordance with EN 61581-1 guidelines. These measurements should also be carried out with the adapter in the "C mode."

Conduct the measurements using appropriate instruments on the measuring sockets of the test adapter. The measured values must adhere to the requirements established for the selected circuit breaker.

### • Testing Integrated DC Residual-Current Detection:

To perform these tests, connect the charging coupler to a test adapter for vehicle simulation as per EN 61581-1 standards, ensuring that the adapter is in the "C mode."

Conduct the measurements using suitable instruments on the measuring sockets of the test adapter.

If the detected residual current exceeds 6 milliamperes (mA) DC, the charging system should disconnect the charging coupler from the power supply, and the system's fault indicator must be activated.

### • Testing Integrated AC Residual-Current Detection:

For these assessments, connect the charging coupler to a test adapter for vehicle simulation in line with EN 61581-1 standards. Perform the measurements with the adapter set in the "C mode." Conduct measurements using appropriate instruments on the measuring sockets of the test adapter.

If the observed residual current exceeds 30 milliamperes (mA) AC, the charging system should disconnect the charging coupler from the power supply, with a tripping time not exceeding 40 milliseconds. The system's fault indicator should also be activated. Note that if the upstream Residual Current Devices (RCDs) are properly dimensioned, they should not trip.

### • Testing Upstream RCD:

Due to the integrated AC residual-current detection, the upstream RCD should be tested at the connection point of the power supply line to the charging system within the building's electrical cabinet.

## 1.12 Operator control elements

### LED Functionality:

The LED serves as an indicator for the charging system's operational status. For detailed information regarding these operational states, please refer to the operating manual.

### Initiating the Charging Process:

The charging process will commence automatically once the charging coupler is plugged in and the vehicle requests a charging session.

### Terminating the Charging Process:

To halt the charging process, follow one of the following methods:

1. Utilize the vehicle's operational control, as described in your vehicle's owner's manual.
2. Disconnect the charging station from the power source by switching off the corresponding circuit breaker in the building.
3. Employ the Astreea® Charger app to cease the charging session.



**The charging process can be stopped by using the mobile application or the vehicle control system.**

**If the automatic magnetic lock fails, do NOT attempt to remove the cable during the charging process.**



**Individuals with pacemakers or defibrillators should refrain from engaging in any tasks or being in proximity to the charging systems and associated devices.**

**This includes activities such as maintenance operations or addressing any faults.**

### 1.13 The structure of your Astreea® Charger

#### Structure of Astreea® Charger:

1. Body
2. Status LED light
3. Protective cover
4. Charging plug
5. Charging cable
6. Antenna and NFC controller
7. Power line connection\*

\*The power source can be linked either underground through the ground fixture or above ground by utilizing the rectangular opening.

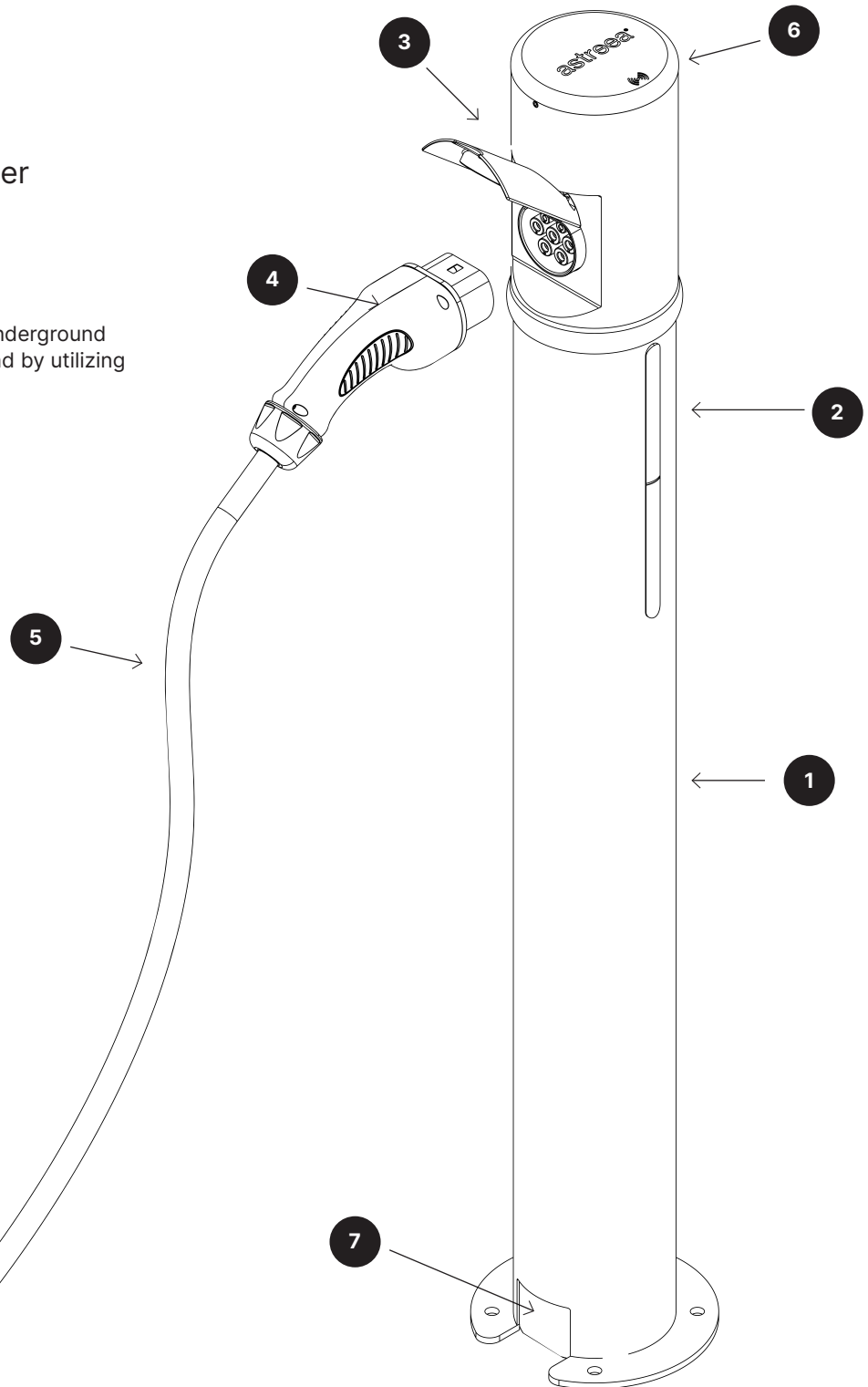

# Discover our EV chargers

## Self Standing 22 kW

Single Socket or Cable Charger

Model:	ACS111-11, ACS111-12, ACS111-21, ACS111-22
Max Output Power:	11 / 22 KW
Output Connection:	Type 2 Charging Socket
Cable available:	Yes (optional)
Mid Meter available:	Yes (optional)
Commercial use:	Based on user choice
Customizable:	Yes (optional)



## Self Standing 2 × 22 kW

Double Socket or Double Cable Charger

Model:	ACS121-11, ACS121-12, ACS121-21, ACS121-22
Max Output Power:	2×22 KW
Output Connection:	Type 2 Charging Socket
Cable available:	Yes (optional)
Mid Meter available:	Yes (optional)
Commercial use:	Based on user choice
Customizable:	Yes (optional)

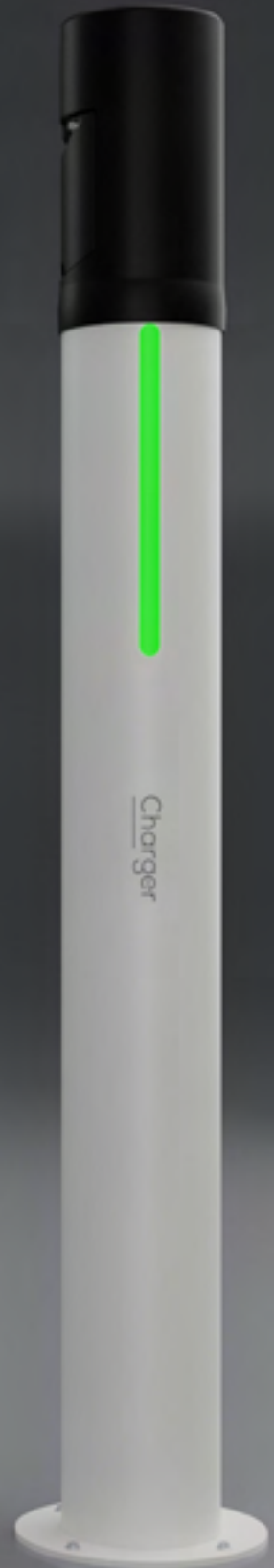

## Wallbox 22 kW

Single Socket or Cable Charger

Model:	ACS211-11, ACS211-12, ACS211-21, ACS211-22
Max Output Power:	22 KW
Output Connection:	Type 2 Charging Socket
Cable available:	Yes (optional)
Mid Meter available:	Yes (optional)
Commercial use:	Based on user choice
Customizable:	Yes (optional)



## Wallbox 2 × 22 kW

Double Socket or Double Cable Charger

Model:	ACS221-11, ACS221-12, ACS221-21, ACS221-22
Max Output Power:	2×22 KW
Output Connection:	Type 2 Charging Socket
Cable available:	Yes (optional)
Mid Meter available:	Yes (optional)
Commercial use:	Based on user choice
Customizable:	Yes (optional)



## 2. Technical Data

Vehicle Connection	Chargers with 1 socket	Chargers with 2 sockets
Type 2 charging socket	16 A* / 32A	2 x 16 A* / 32A
Maximum charging current	16 A / 32 A	2 x 16 A / 32 A
Maximum charging power	11 kW / 22 kW	2 x 11 kW / 22 kW
Output voltage	230 / 400 V	

Protections	
Required protections	External type ARCBO, ground fault including DC residual current protection, external surge protection
Protection Class	IP54
Mechanical Protection	IK10
Operating Temperature	-30C to 50C
Humidity	5% - 95% without condensation

Communication and protocols	
Interface	Astreea® Mobile Application iOS / Android, RGBW LED
Protocols	* Wi-Fi, Modbus TCP, NFC type A, OCCP 2.0, Ethernet/LAN, LTE 4G
Protocols	* Dynamic Load Balancing, Meter or MID Meter integration, Interactive in-app Map, RFID & NFC authorization, charging history, Real-time Configurable Maximum Power, User management and privilege system, Solar Panel integration, Remote cloud support, Charging Scheduler, Smart Home compatibility, Web-based Analytics Platform

**Mandatory power connections**

<b>Nominal voltage</b>	230 / 400V
<b>Nominal current</b>	16 A / 32 A
<b>Circuit Breakers</b>	20 A / 40 A, 3-poles
<b>AC fault detection</b>	RCCB, Type A, 30mA

\*Some software features and systems may still be in the development phase at the time of purchase.

Horizontal Wallbox

ACS311

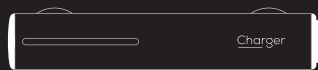

Self Standing

ACS121

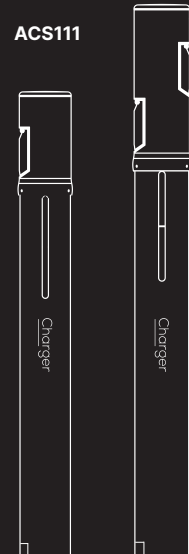

Wallboxes

ACS221

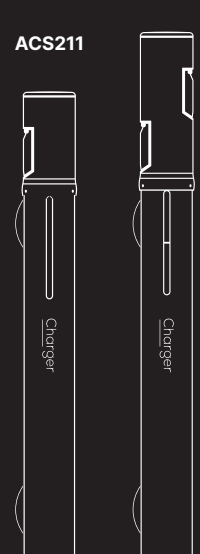

Scan for:  
astreea.com/charger

**Remember**

There are **5 different models** serving one purpose: making e-charging the coolest thing there is.



**Missing or you lost spares?** Please call our customer service: (907) 931-4469

### 3. Assembly. Anchoring with foundation and metal frame.

#### 3.1. Creating the foundation

To ensure the secure and stable installation of the Charger, Astreea® recommends utilizing the optional Stainless steel Foundation Frame, which is embedded in concrete. It is essential to prevent any cement from entering the threaded holes during this process.

Additionally, it's crucial to take precautions to avoid damaging or scratching the electrical cables and their protective coverings during installation. The use of pre-made bolting points simplifies the assembly of the charging column:

- If necessary, you can adjust the height as needed.
- Begin by excavating the ground and forming a shutter for the foundation area.
- Insert the Foundation Frame and thread an empty conduit through the designated opening.
- While aligning the base frame, pay attention to the front mark located on the mounting plate. This indicates which way the LEDs will be facing
- Guide the supply line through the empty conduit.
- Leave an ample length above the ground surface.
- Level the foundation frame to ensure that the foundation plate is flush with the ground.
- Verify that there are no exposed electrical wires visible after completing the installation.



**Make certain that the selected foundation possesses the necessary structural strength to endure the forces exerted during the installation procedure.**

**Concrete is recommended.**

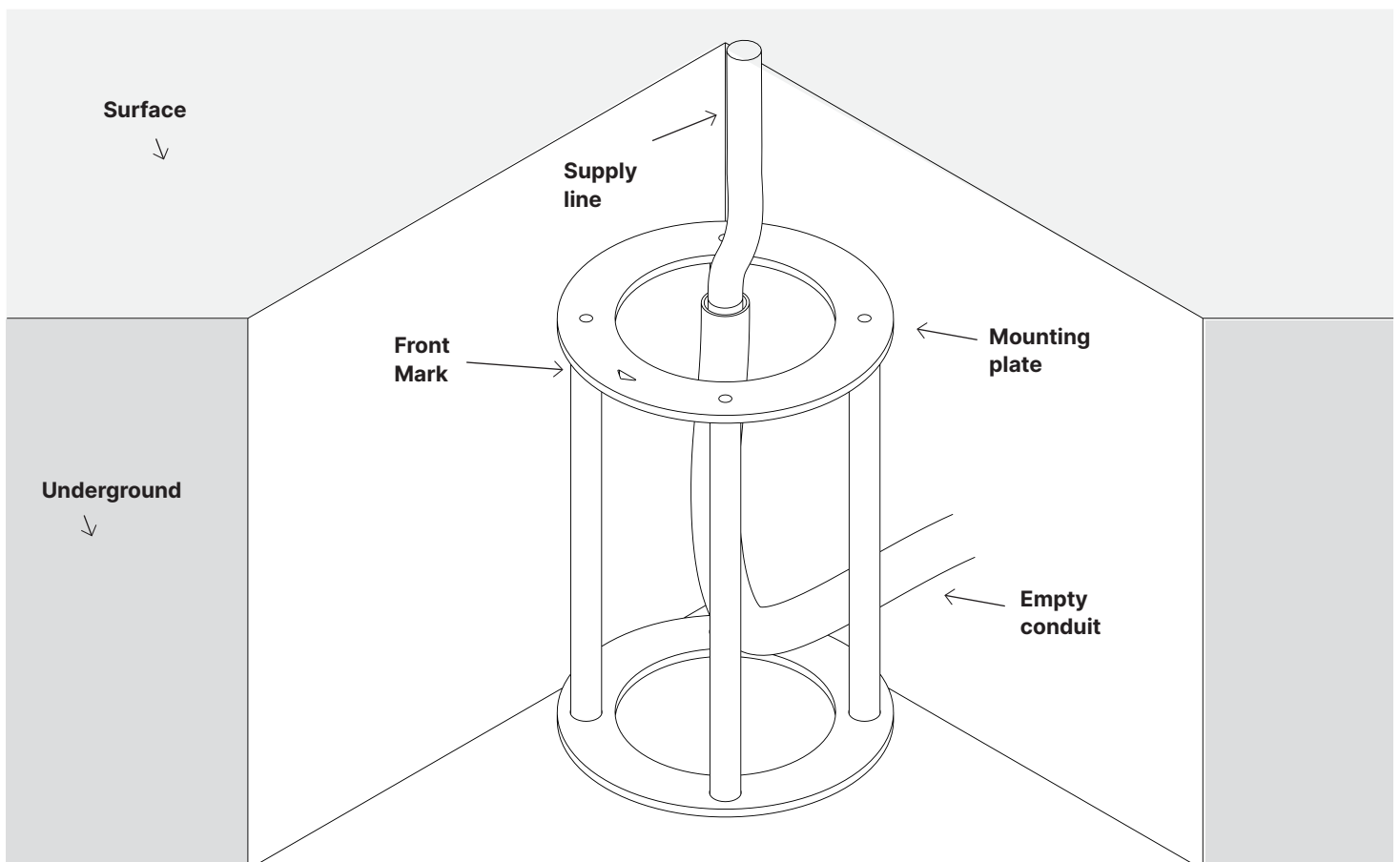

The illustrations portray a charger with only one socket. There could be some minor variations in other models.

### 3.2. Mount the sleeve on the lower cap

**Once the foundation has solidified, follow these steps:**

1. Detach the Lower Cap from the interior of the charger by pulling down.
2. Attach the Sealing Sleeve to the Lower Cap in the designated position.
3. Place the Lower Cap onto the Foundation Frame, following the visual references provided in the images below.

Ensure the sleeve is securely positioned on the socket, free from any creases or debris. Properly tighten the Cable Gland to prevent water condensation.

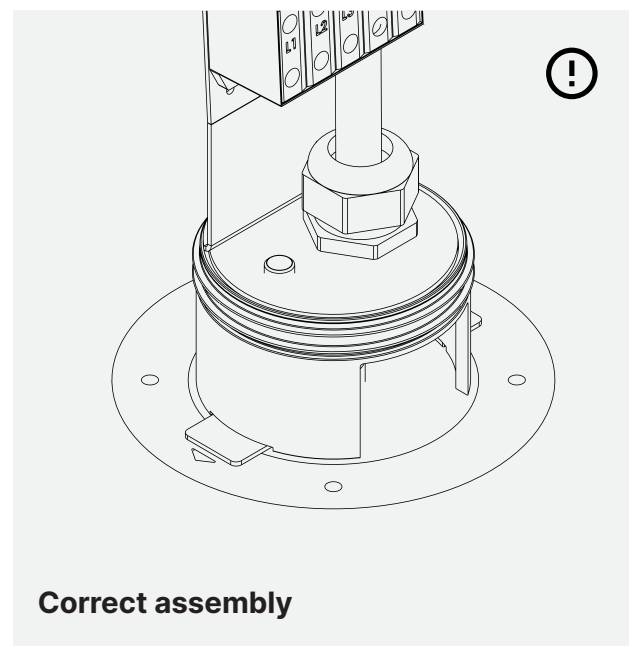
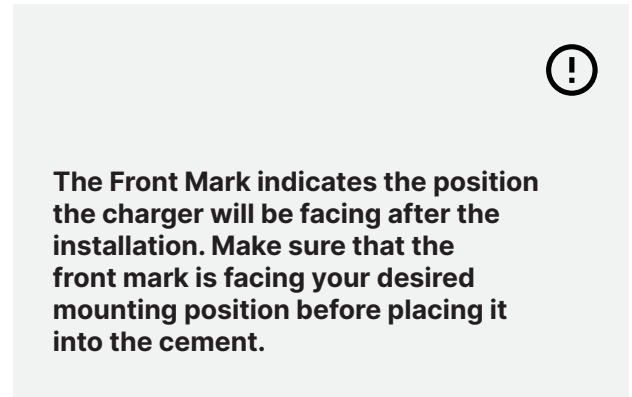
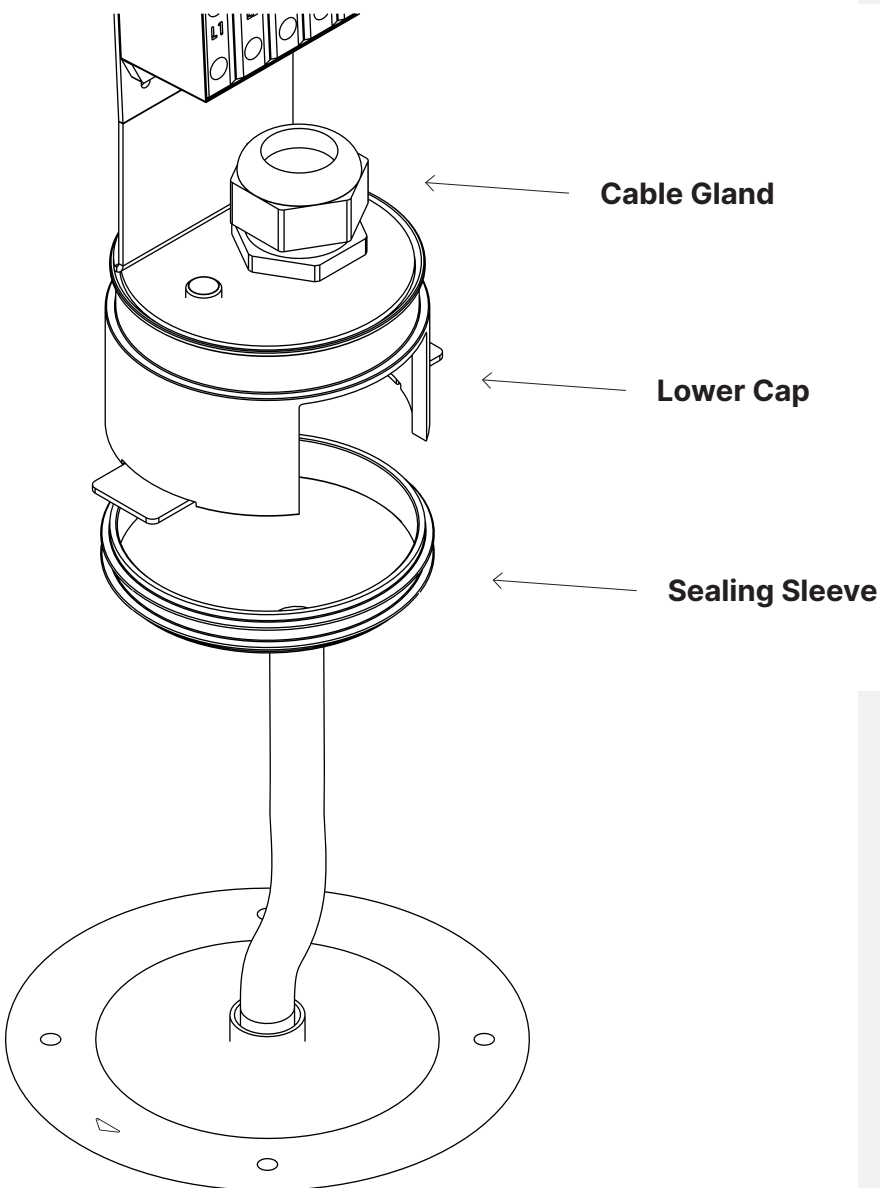

The illustrations portray a charger with only one socket. There could be some minor variations in other models.

## 4. Linking the wires

### 4.1 Feed the supply cables through the cable gland

Pull the cables through the cable gland, adjust the length of the wires and strip off the jacket making sure to leave out at least 10 mm at the top.

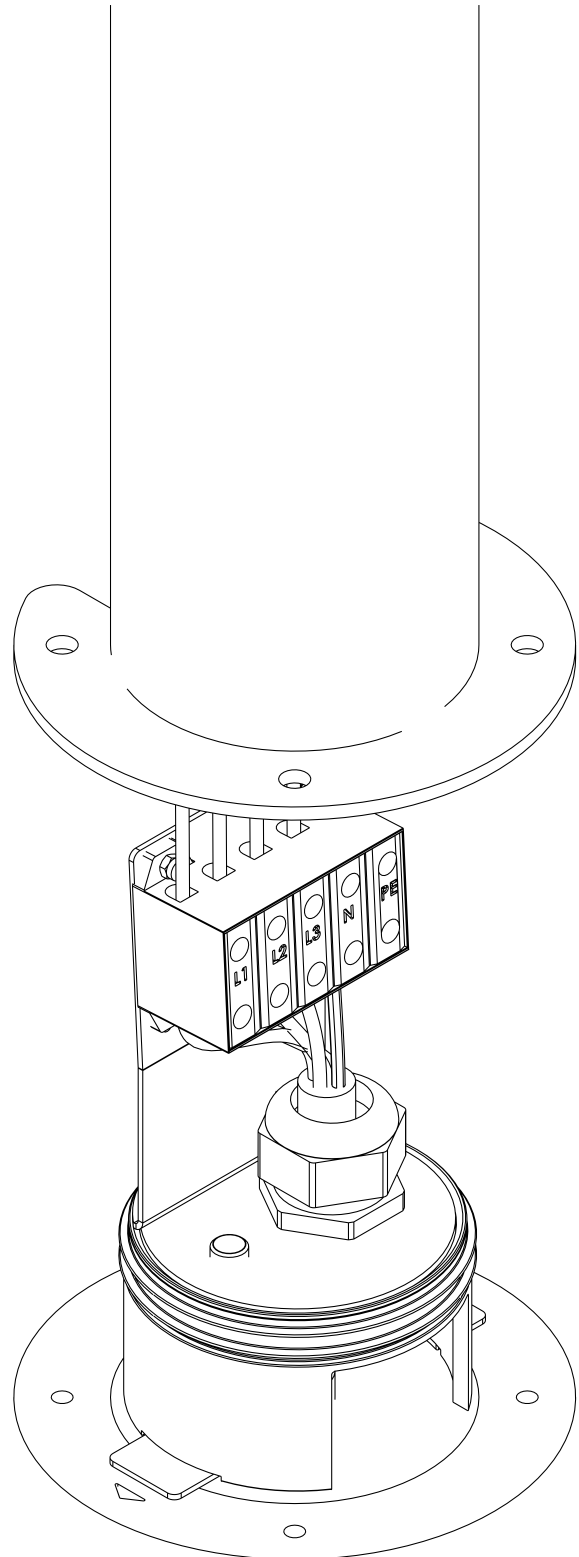

The illustrations portray a charger with only one socket. There could be some minor variations in other models.

## 4.2 Link the wires to the terminal strip

After you've customized the wire length and removed the cable insulation, proceed to connect the wires. Refer to the connection diagram in the table below, which illustrates how to connect the ground-side supply line to the charging unit cables along with their respective functions. Ensure the wires are connected accurately, as failure to do so could result in charger damage or personal injuries.

Supply Line Ground		Terminal Strip	Loading Unit	
Colour	Function	Label	Colour	Function
Brown	Phase 1	L1	Brown	Phase 1
Black	Phase 2	L2	Black	Phase 2
Grey	Phase 3	L3	Grey	Phase 3
Blue	Neutral Conductor	N	Blue	Neutral Conductor
Green/Yellow	Protective Conductor	PE	Green/Yellow	Protective Conductor

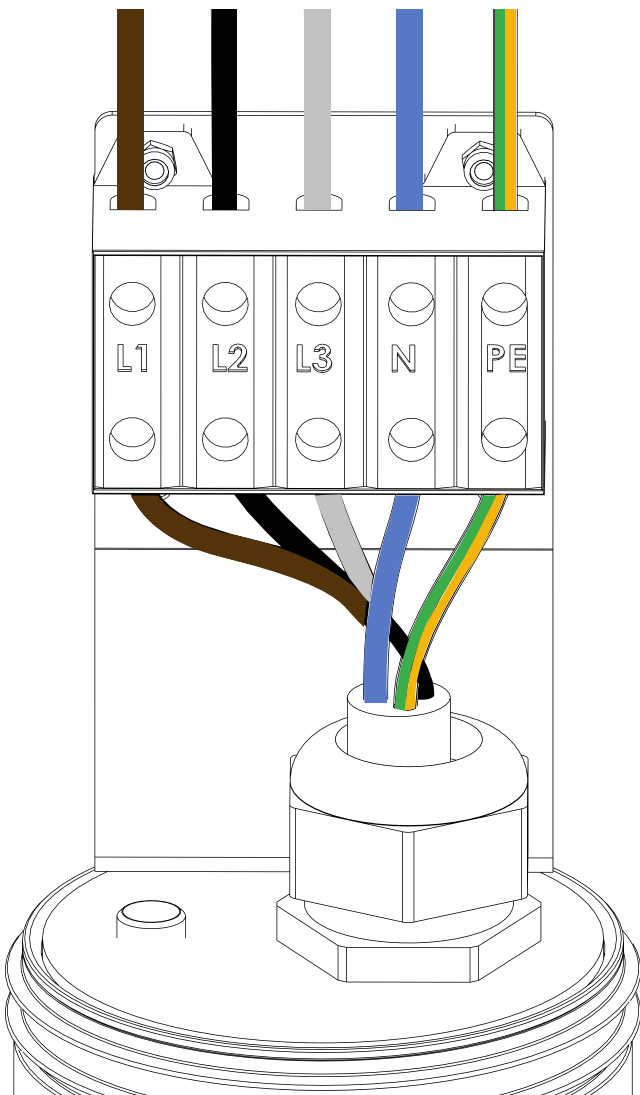

**Only qualified personnel should undertake the electrical installation of the charging station.**

**During the electrical system installation, it is crucial to prevent cable damage or compression, as these issues could disrupt functionality in the future, lead to defects, or even trigger a fire.**

The illustrations portray a charger with only one socket. There could be some minor variations in other models.

## 5. Finishing the installation

### 5.1 Fix the charger to the foundation

After securely connecting the cables, carefully insert the socket back into the Charger and position it over the Foundation Frame. Ensure that the holes in the Charger's base align with those in the Foundation Frame.

To affix the charger to the Foundation Frame, utilize 4 x M8 domed head screws, which are provided. If you attempt to affix the charger without the Foundation Frame, use conexpands instead.

**Remember to apply pipe lubricant on the sealing before reinserting the socket into the charger.**

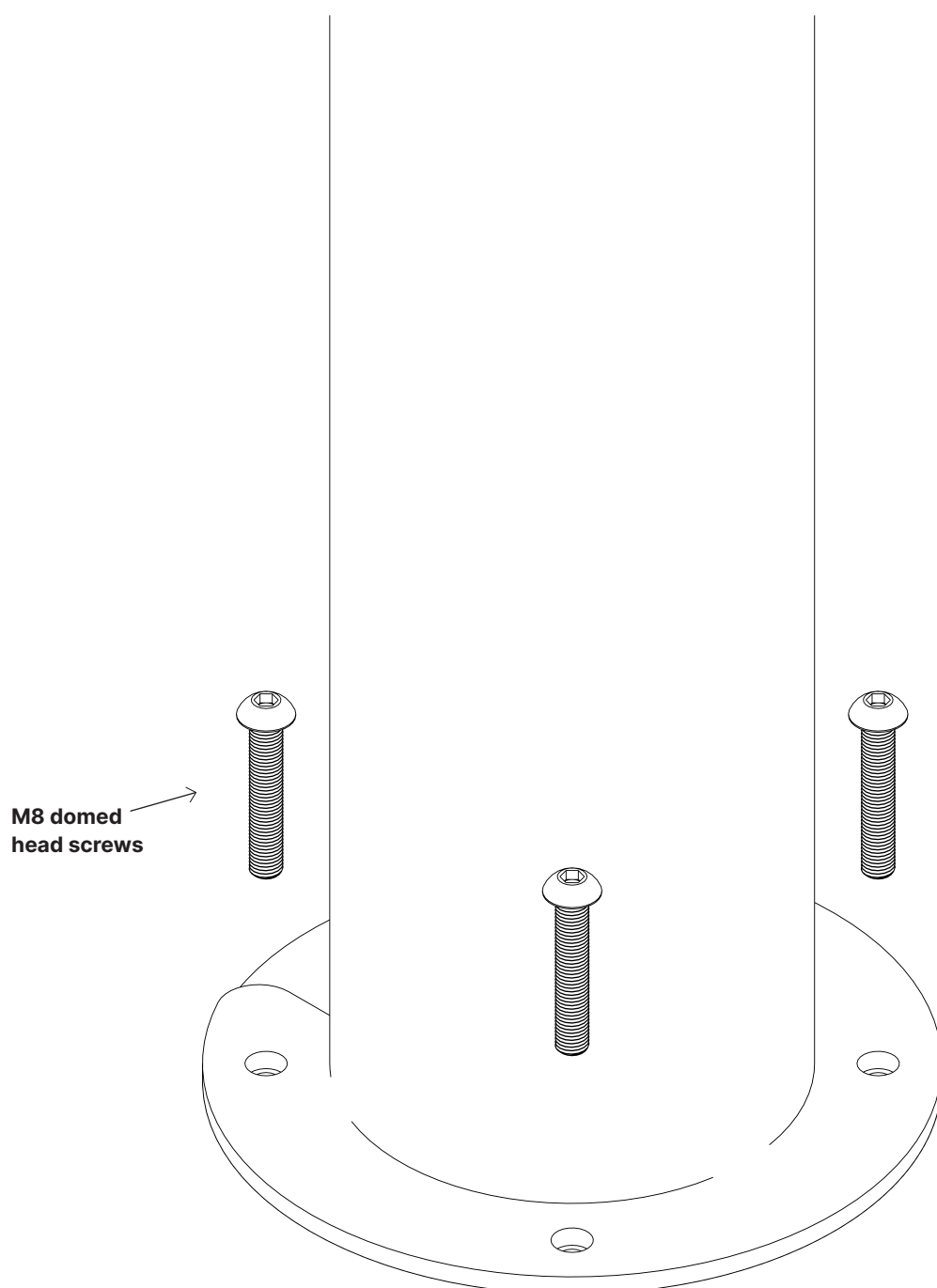

ASTREEA® CHARGER SELF STANDING

# READY TO USE

Scan the QR code provided on the Certificate of Conformity and follow the instructions within the mobile application to register your charger.

If you possess a double socket charger, be sure to scan both QR codes.



**A sluggish or unreliable internet connection can result in the mobile application not functioning as expected, leading to delayed responses and potential crashes. It's essential to ensure a stable internet connection is maintained for both the charger and the mobile app to operate smoothly.**

**astreea®**

Made in EU  
Astreea Charger

Voltage: 3 × 400V AC  
3P+N+PE

Input current: 32A

Output current: 32A

Frequency: 50Hz

Protection class: IP54

Tmin/max: -30°C/+50°C

[astreea.com/charger](http://astreea.com/charger)

The Astreea® Charger includes a sticker that contains crucial information about the charging station. Whether or not you choose to affix the sticker to the charger body is entirely optional.

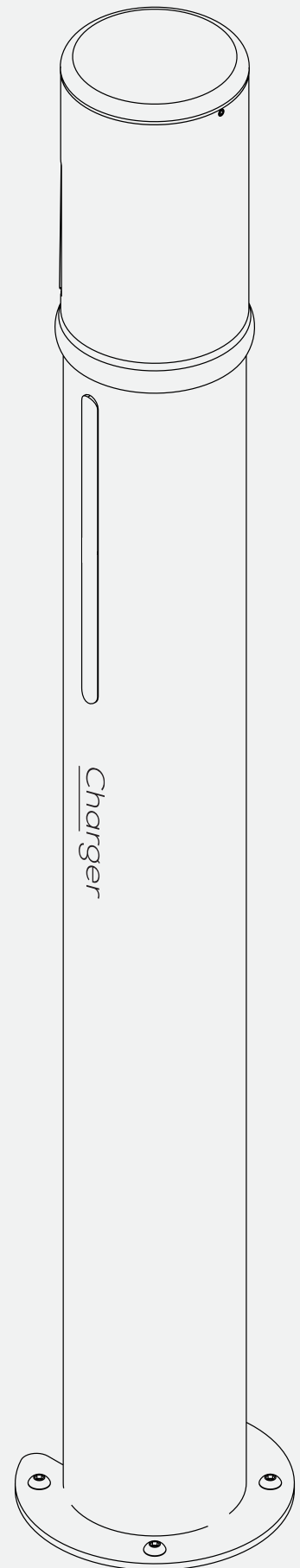

astrøea®

# Installation guide for wall chargers

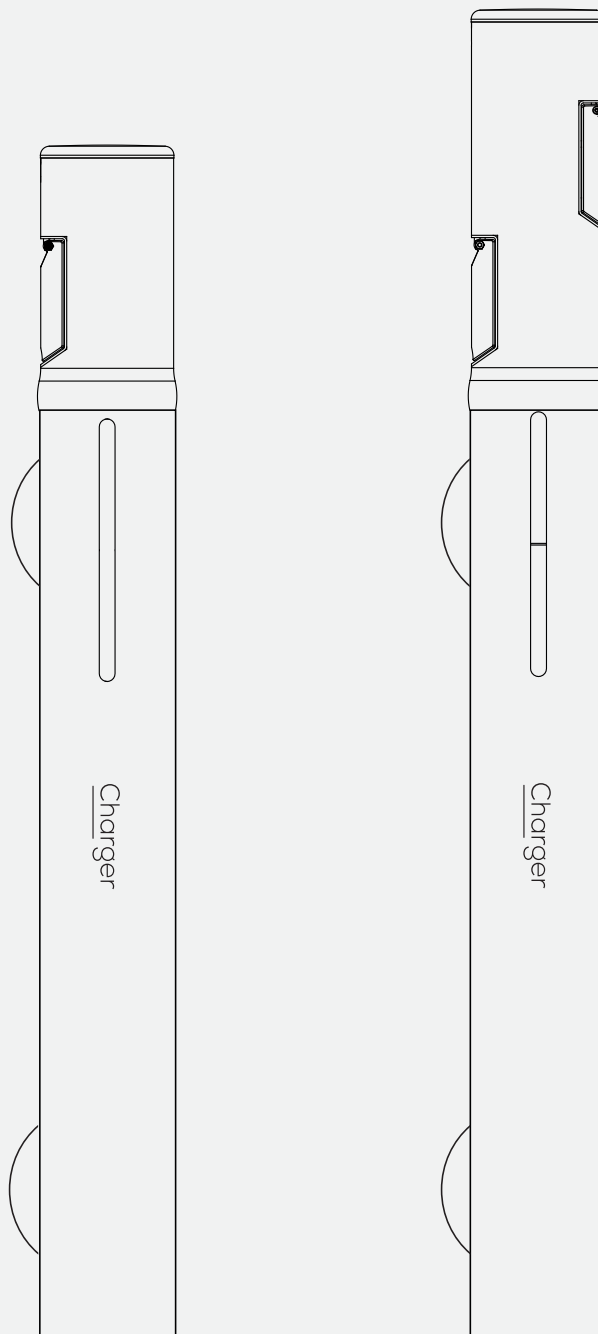

# 1. Anchoring the charger to the wall

## 1.1 Choosing the installation surface

Prior to charger installation, it is essential to select an appropriate mounting surface capable of enduring both the installation process's forces and the everyday wear and tear of the charging station.

Astreea® suggests utilizing concrete as the preferred mounting surface, ensuring it possesses the necessary physical characteristics suitable for both installation and long-term use.

**Step 1.** Mark a line with a length of approximately 90mm at a height of 950mm from the ground. Ensure that this line is perfectly horizontal using a level.

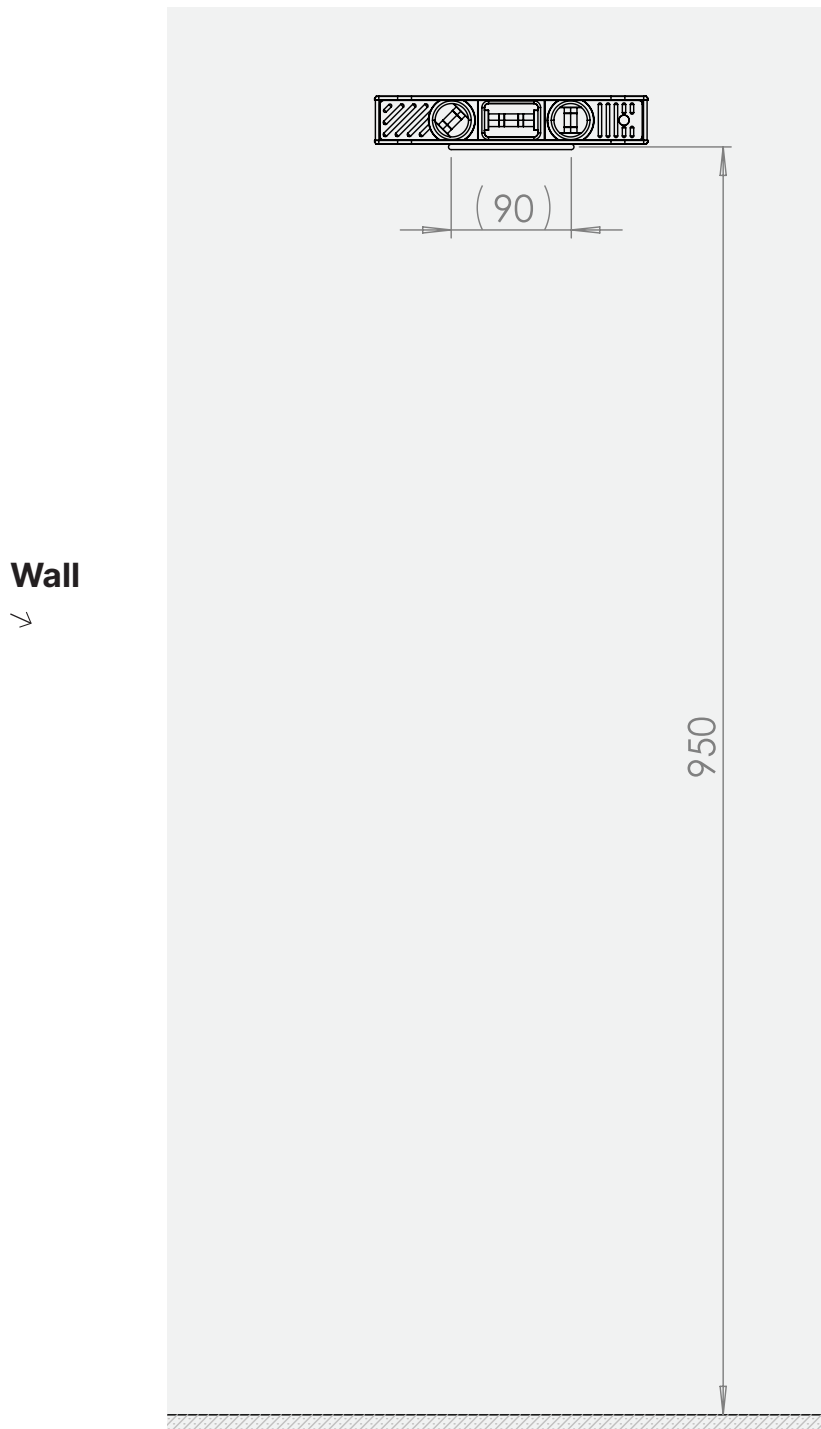

## 1.2 Mounting on the chosen surface

**Step 2.** Place the support piece on the wall, aligning the hole marked at the bottom with the other two holes matching the line drawn on the wall, marking the positions of the fastening holes. The diameter of these holes is determined by the chosen fastening system. The fastening system is not included in the package; it should be selected based on the type of wall for the installation.

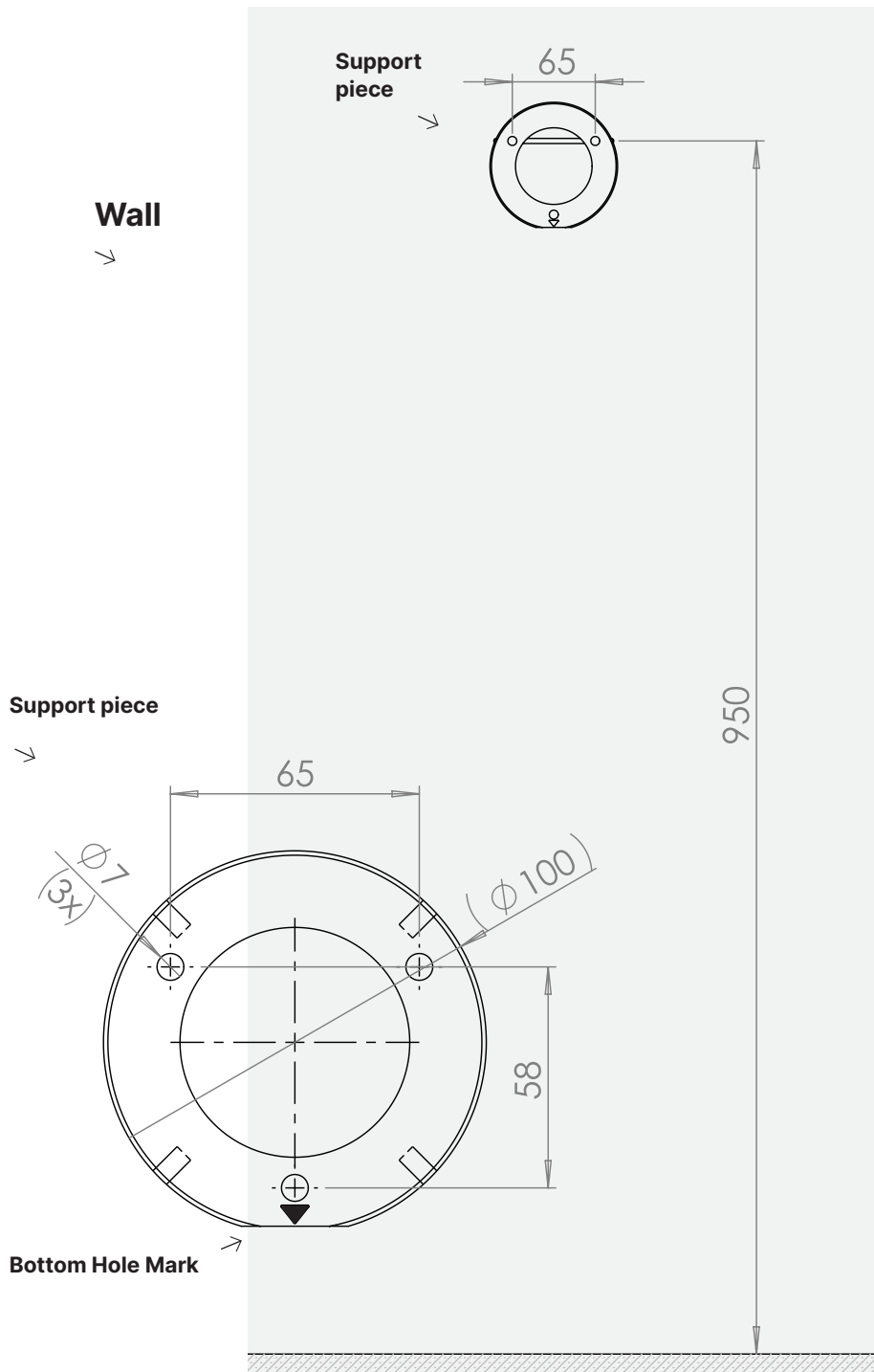

The illustrations portray a charger with only one socket. There could be some minor variations in other models.

### 1.3 Mounting on the chosen surface

**Step 3.** After attaching the support piece to the wall, you should mark the positions of the other two fastening holes for the lower support according to the specified measurements. Pay close attention to their alignment, ensuring they are perfectly vertical and centered with respect to the support piece.

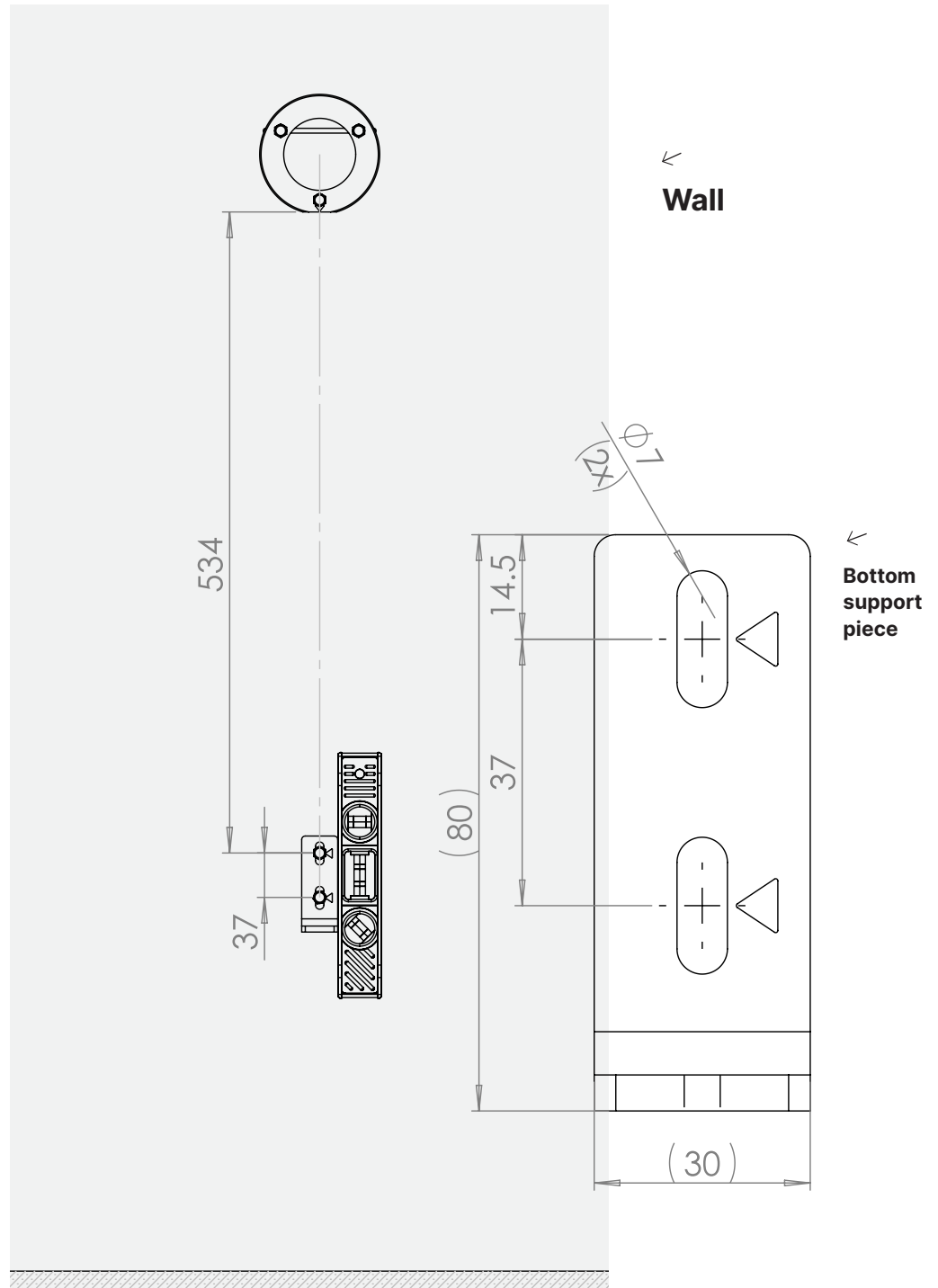

**CAUTION:**  
When securing the lower support, make sure it aligns vertically.

The illustrations portray a charger with only one socket. There could be some minor variations in other models.

## 1.4 Mounting the Inferior Cap

1. Unscrew the two M5×10 screws to remove the bottom cover of the station.
2. Detach the WAGO female connector.
3. Screw the conduit gland onto the bottom cover.

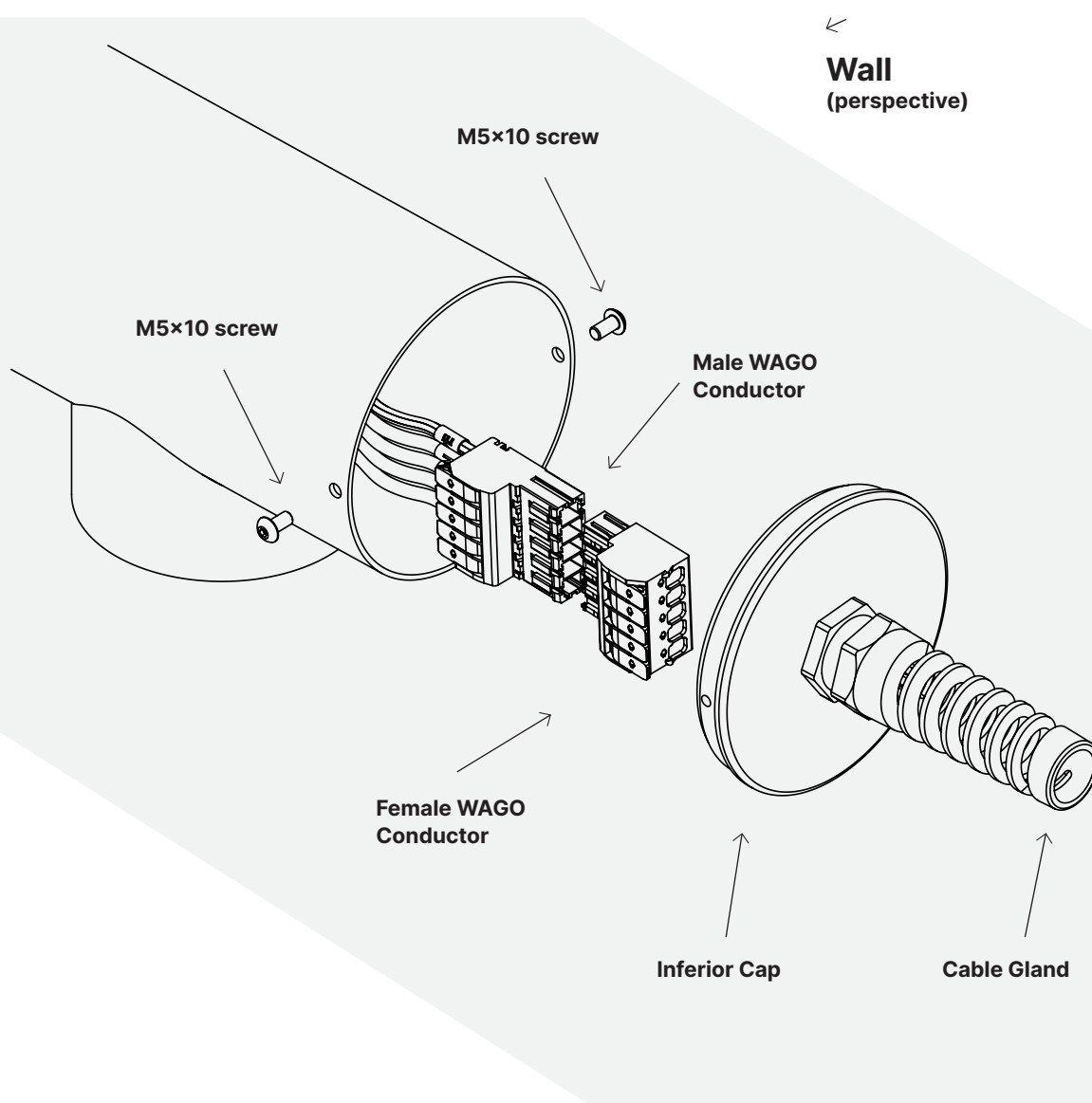

The illustrations portray a charger with only one socket. There could be some minor variations in other models.

## 1.5 Mounting on the wall

Position the station on the wall, using the support piece, while also checking if the lower support needs to be adjusted vertically. If repositioning is required, ensure that the station is securely fastened both at the bottom and the top. Tightening the screws should only be done once all fastening screws have been partially threaded in.

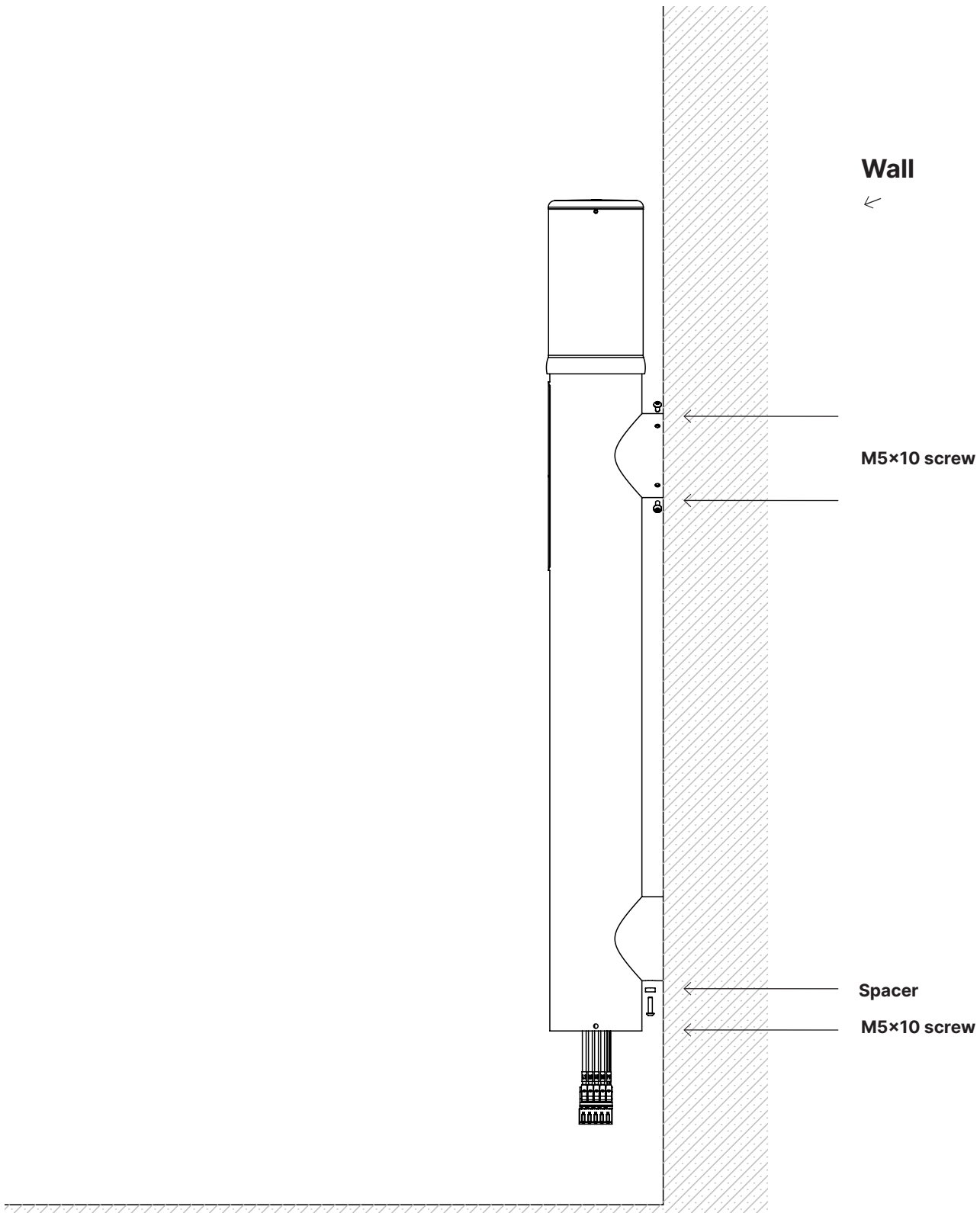

The illustrations portray a charger with only one socket. There could be some minor variations in other models.

## 2. Linking the supply line and wires

The power cable should be passed through the conduit gland and the first bottom cover. Connect the wires to the WAGO female connector according to the following diagram:

Supply Line Ground		Terminal Strip	Loading Unit	
Colour	Function	Label	Colour	Function
Brown	Phase 1	L1	Brown	Phase 1
Black	Phase 2	L2	Black	Phase 2
Grey	Phase 3	L3	Grey	Phase 3
Blue	Neutral Conductor	N	Blue	Neutral Conductor
Green/Yellow	Protective Conductor	PE	Green/Yellow	Protective Conductor

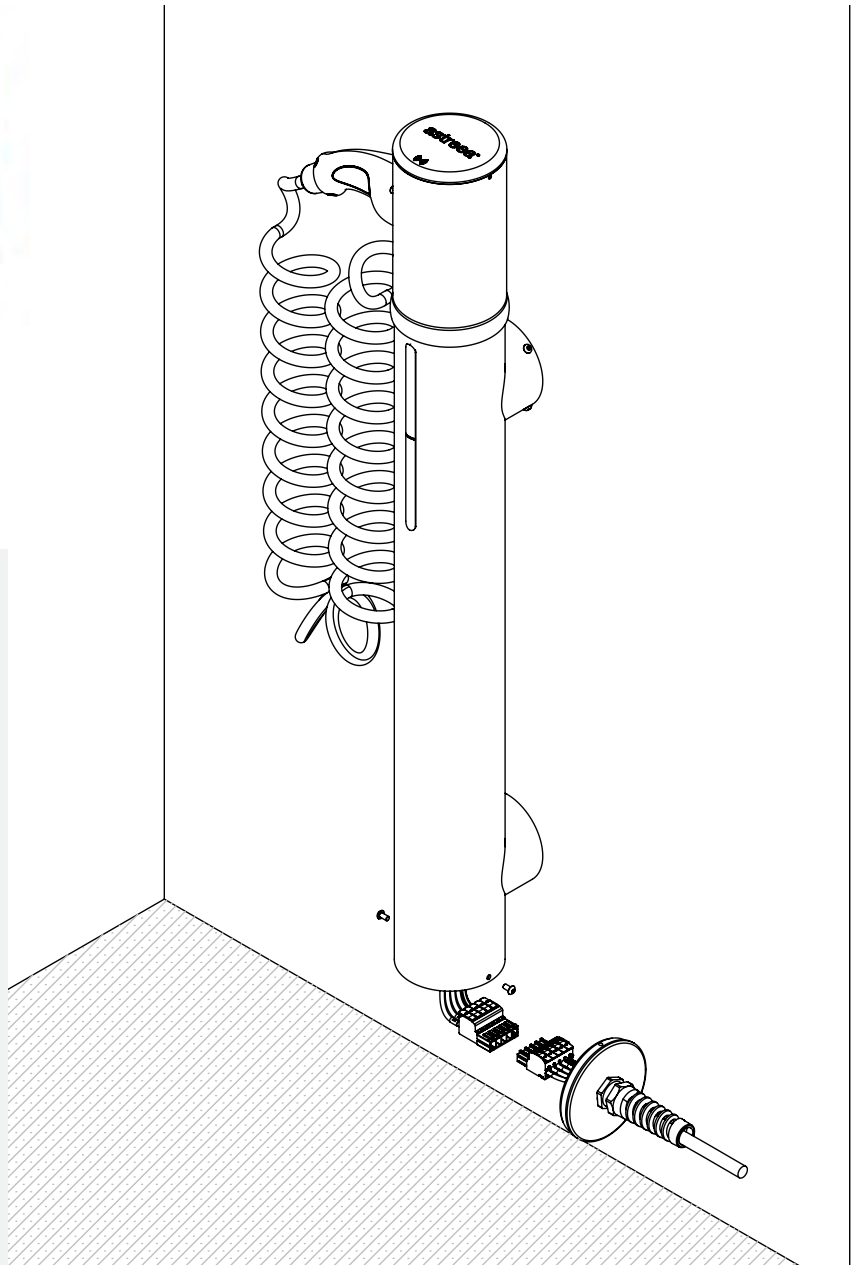

**Only qualified personnel should undertake the electrical installation of the charging station.**

**During the electrical system installation, it is crucial to prevent cable damage or compression, as these issues could disrupt functionality in the future, lead to defects, or even trigger a fire.**

The illustrations portray a charger with only one socket. There could be some minor variations in other models.

### 3. Finishing the installation

Mount the bottom cover onto the station body by tightening the two M5×10 screws. After tightening the screws, also tighten the conduit gland nut to ensure a proper seal.

**CAUTION:** Make sure the cable sheath reaches inside the station, and avoid tightening the conduit gland over the individual wires.

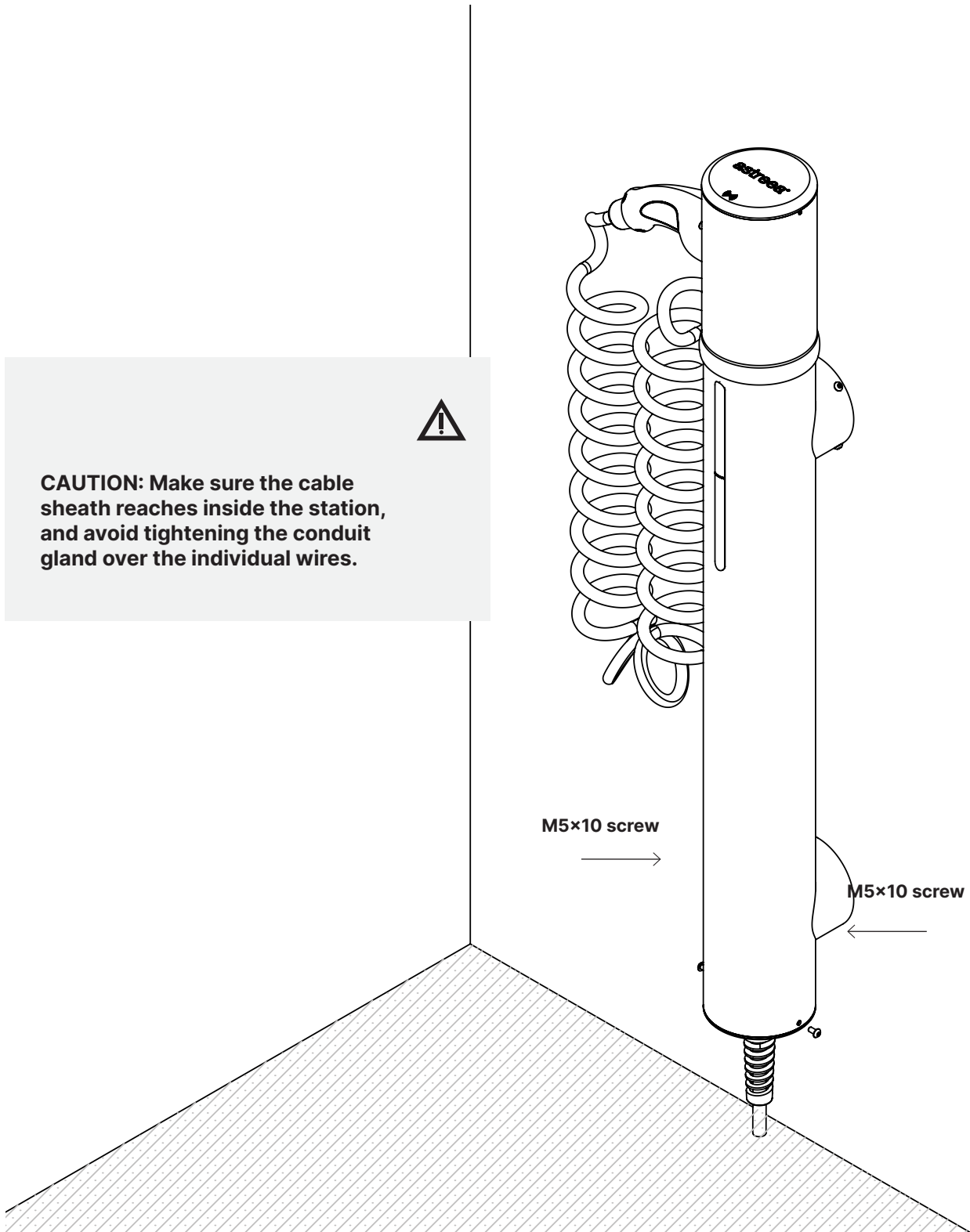

The illustrations portray a charger with only one socket. There could be some minor variations in other models.

ASTREEA® CHARGER SELF STANDING

# READY TO USE

Scan the QR code provided on the Certificate of Conformity and follow the instructions within the mobile application to register your charger.

If you possess a double socket charger, be sure to scan both QR codes.



**A sluggish or unreliable internet connection can result in the mobile application not functioning as expected, leading to delayed responses and potential crashes. It's essential to ensure a stable internet connection is maintained for both the charger and the mobile app to operate smoothly.**

**astreea®**

Made in EU  
Astreea Charger

Voltage:	3 × 400V AC 3P+N+PE
Input current:	32A
Output current:	32A
Frequency:	50Hz
Protection class:	IP54
Tmin/max:	-30°C/+50°C

[astreea.com/charger](http://astreea.com/charger)

The Astreea® Charger includes a sticker that contains crucial information about the charging station. Whether or not you choose to affix the sticker to the charger body is entirely optional.

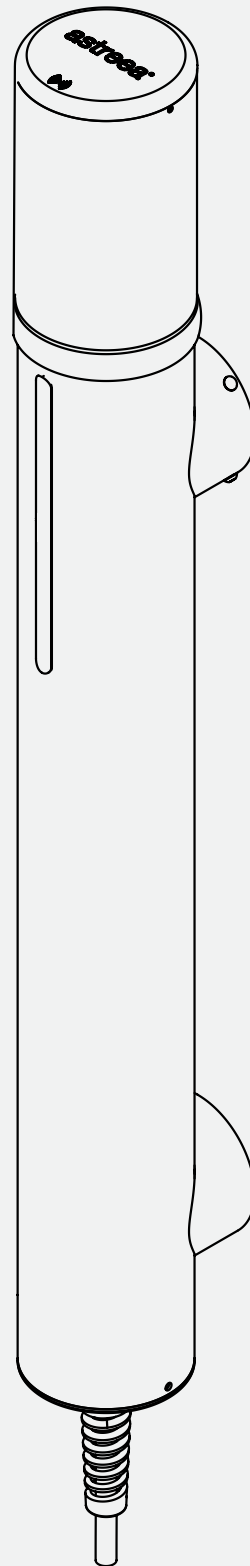

# USAGE OPERATIONS

## 1. LED status indicator

The Astreea® Charger is equipped with an integrated status monitoring system, which relies on the installed RGBW LED.

The LED's colors are preset and cannot be customized by the user during installation. Each color corresponds to a potential state of the charger, offering live information regarding the station's condition.



**If the LED bar is not illuminated, it may indicate an issue with either the power system or the LED bar itself. It is advisable to reach out to Astreea® Support for assistance in such cases.**

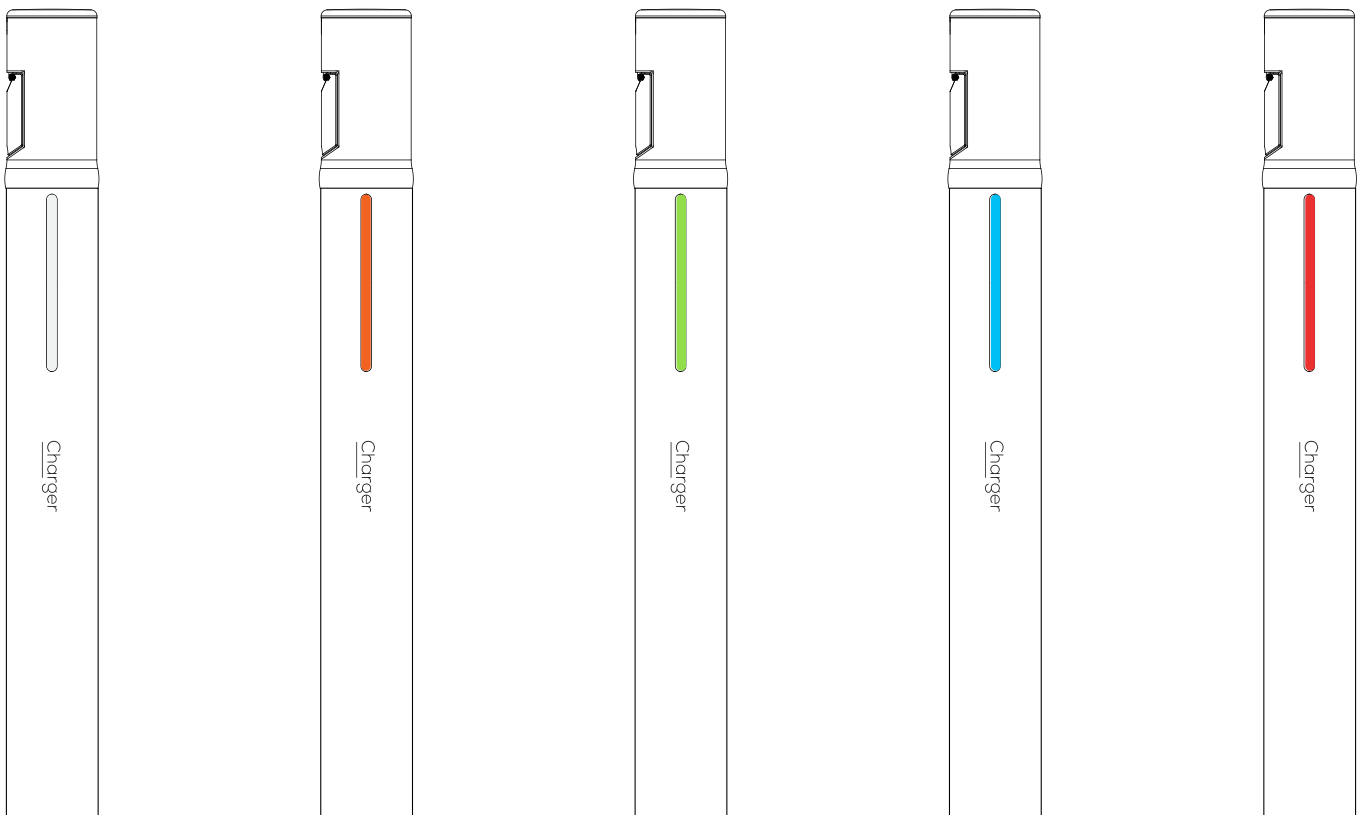

### THE COLORS REPRESENT:

- **White:** The charger is in the process of initializing and downloading the most recent software update, if one is available.
- **Orange:** The station is waiting for enrollment. This may occur during the initial setup of the charger or when the connection to Wi-Fi is lost.
- **Green:** The charger is ready for charging.
- **Blue:** The charger is waiting for authorization via the app or an NFC/RFID card.
- **Blue – pulsating:** The charging process is currently in progress.
- **Red:** The station has encountered a fault. Please contact Astreea® Support for assistance.

## 2. Astreea® Charger App

### How to use the mobile app

Privacy notice - tap "Continue" after reading the privacy notice

Login screen - enter your account details or login with your Apple account



After log in - tap "Start pairing" button and enable the Camera Permission in order to scan the QR Code provided to you in the Certificate of Conformity.

After scanning the code, connect the charger to your local Wi-Fi network and wait for the enrollment to finish.



Charging screen - you have a full status of your Charger(s), the duration and costs for each and additional settings

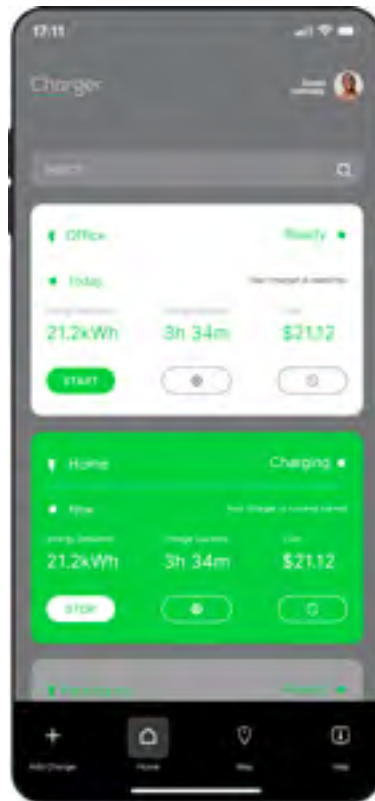

Status screen - you'll get a full status of your charge

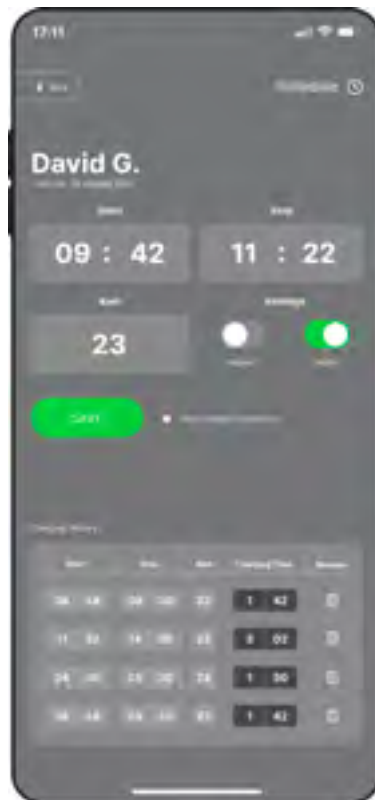

You can schedule your charges according to your needs and also keep track of everything





## Certified by:



*Missing or you lost spares?* Please call our customer service: (907) 931-4469



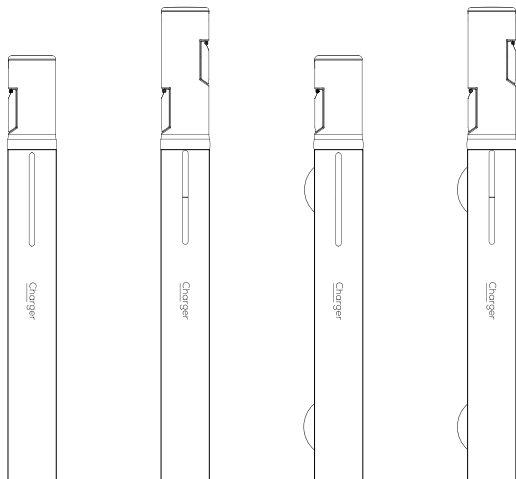

## EV Charger – All Vertical Models

ACS111, ACS121, ACS211 and ACS221  
(11KW/22KW) and subsets.



Scan for:  
[astreea.com/charger](https://astreea.com/charger)