

Table 15. Technical data ARS pro

Parameter		ARS 00/60 mm pro	ARS 00/100 mm pro	ARS 400 pro	ARS 630 pro	ARS 630 kVA pro	RWS 600 pro	RWS 750 pro	RWS 1250 pro	ARS 1250 pro
Rated thermal current $I_{th}=I_n$ with fuse links	A	160	160	400	630	910	-	-	-	1250
Rated thermal current I_{th} with solid links	A	-	-	-	-	-	600	750	1250	-
Rated voltage U_n	V	690	690	690	690	400	690	500	400	400
Utilization category	690 V	AC-22B	AC-22B	AC-22B	AC-22B	-	AC-22B	-	-	-
	500 V	-	-			-		-		
	400 V	AC-23B	AC-23B	AC-22B	AC-22B	AC-22B		AC-21B		
Rated switching current I_e	A	160	160	400	630	910	600	750	1250	1250
Rated short-circuit making current	690 V	kA	80	25	100	100	-	-	-	-
	500 V		120		120	120	-	-	-	-
	400 V		-	-	50	-	-	-	100	
Rated short-circuit withstand current	690 V	kA	80	100	100	100	-	-	-	-
	500 V		120		120	-	-	-	-	
	400 V		-	-	50	-	-	-	100	
Rated insulation voltage U_i	V	1000	1000	1000	1000	1000	1000	1000	1000	1000
Rated impulse withstand voltage U_{imp}	kV	8	8	12	12	12	12	12	12	12
Rated short time withstand current I_{cw}	kA	-	-	-	-	-	15 ³⁾	15 ³⁾	15/20 ²⁾	-
Rated frequency	Hz	50-60	50-60	50-60	50-60	50-60	50-60	50-60	50-60	50-60
Mechanical durability	Number of cycles	1600	1600	1000	1000	600	1000	1000	600	600
Electrical durability		200	200	200	200	100	200	200	100	100
IP degree of protection	IP	30	30	30	30	30	30	30	30	30
Fuse links size	-	00	00	1,2	3	gTr 630 kVA ¹⁾	solid-links ZN2	solid-links ZN3	solid-links ZN3 -1250 A	3

¹⁾ fuse link gTr 630 kVA, DIN 43620, VDE 0636/2011, size NH3

²⁾ with mechanical lock

³⁾ use of mechanical lock recommended

OPERATING CONDITIONS

- to be installed in the room free of any dust, aggressive or explosive gases,
- altitude up to 2000 meters above sea level,
- outdoor – in cabinets with protection degree > IP 34,
- ambient temperature from -25 °C to +55 °C,
- relative humidity of the air should not be higher than 50% at temperature of +40°.

FUNCTIONALITY

- making and breaking operations should be done with determined movement,
- parallelly moving, double contact system,
- designed for installation on to 60 mm, 100 mm or 185 mm busbar system,
- two versions: single pole switching (separately each pole) or triple pole switching (three poles at the same time),
- width 50 mm (ARS 00/60 mm pro, ARS 00/100 mm pro); width 100 mm (ARS 400 pro, ARS 630 pro, RWS 600 pro, RWS 750 pro, RWS 1250 pro) or 200 mm (ARS 1250 pro),
- suitable for top cable terminal connection,
- possible connection of conductors with lug terminals (screw terminals) or circular/sector-shaped conductors with bare ends (V-terminals, 2V-terminals) using V-clamps,
- voltage test is performed through test holes leading to blade contacts,
- possible installation of various types of earthing devices.

FUSE SWITCH DISCONNECTOR ARS 00/60 mm pro (160 A, 690 V)

Table 16. Technical data

Parameter	ARS 00/60 mm pro		
Rated thermal current $I_{th}=I_n$	A	160	
Rated voltage U_n	V	690	
Utilization category	-	AC-22B	AC-23B
Rated switching voltage U_e	V	690	400
Rated switching current I_e	A	160	
Rated short circuit making current	690 V	kA	80
	500 V		120
Rated short circuit withstand current	690 V	kA	80
	500 V		120
Rated insulation voltage U_i	V	1000	
Rated impulse withstand voltage U_{imp}	kV	8	
Rated frequency	Hz	50-60	
Mechanical durability	Number of cycles	1600	
Electrical durability		200	
IP degree of protection	IP	30	
Fuse links size	-	00	



ARS 00/60 mm pro

ARS 00/60 mm pro

Table 17. Versions

Version of ARS 00/60 mm pro	Article No.
three pole switching - all phases simultaneously (for installation on to 60 mm busbar system)	
ARS 00/60 mm pro cable terminals: bridge terminals with bridge clamps (S) 4-70 mm ² screw terminals with M8 screws	63-002354-001
ARS 00/60 mm-T pro cable terminals: frame clamps 2,5-70 mm ²	63-002354-002

Table 18. ARS 00/60 mm pro terminal clamps

Description	ARS 00/60 mm pro		
Clamp	S-bridge clamp 2 x M5 x 20	screw M8*	frame clamps
Picture of clamp			
Drawing of clamp			
Cross-section of conductors	4 - 70 mm ²	Conductor with lug terminal max 95 mm ²	2,5 - 70 mm ²
Tightening torque	3 Nm**	10 Nm**	6 Nm**

For stranded conductors using cable ferrules is recommended

*) bars of maximum width of 20 mm and maximum thickness of 5 mm can be fixed to M type screw terminals

**) using tension wrench is recommended

ARS 00/60 mm pro

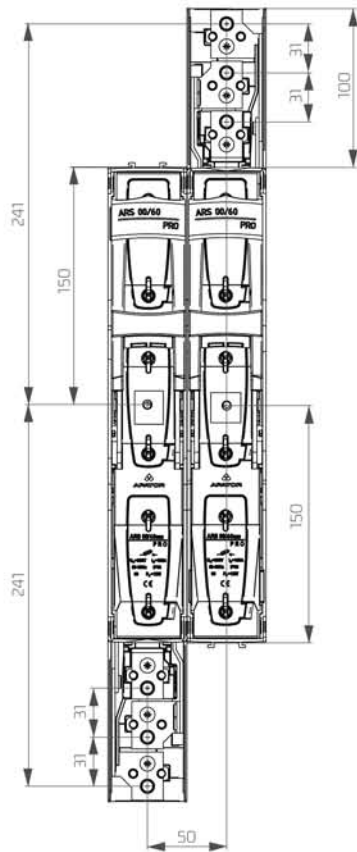

OPENED

PARKED

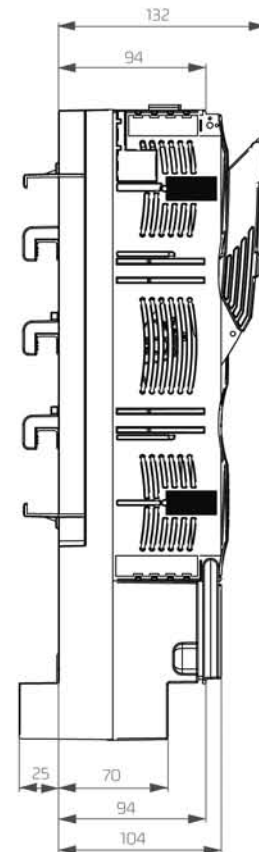
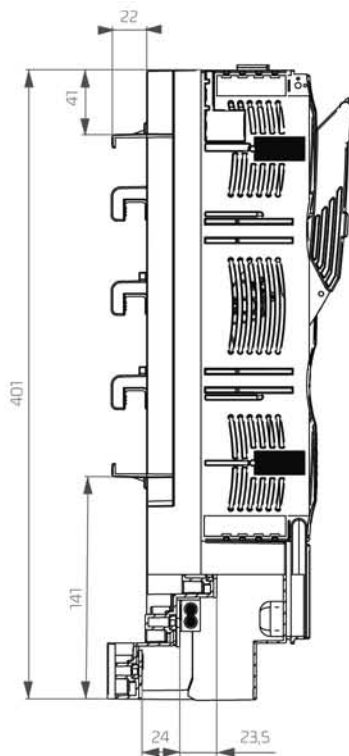
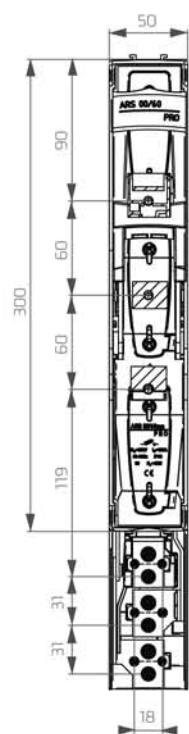
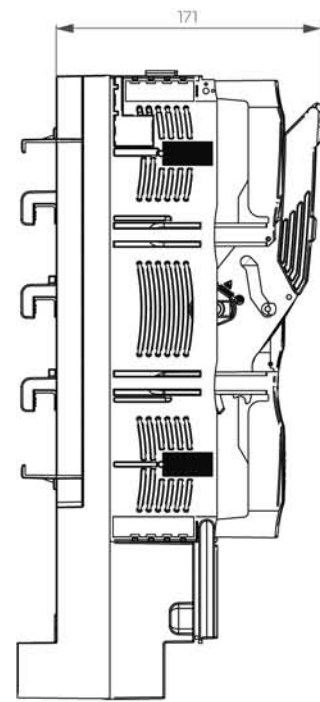
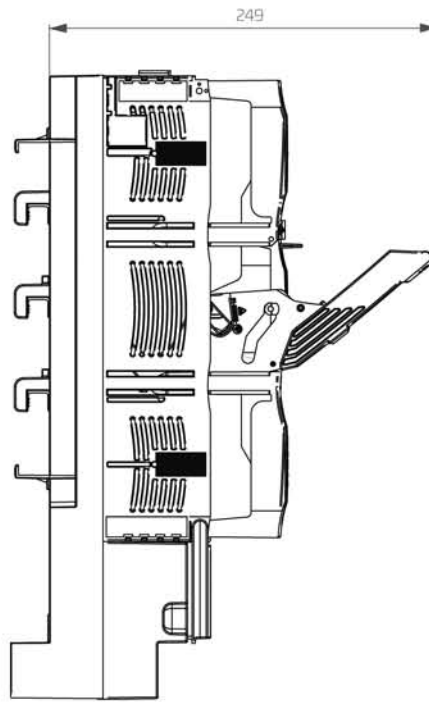

ARS OVERALL DIMENSIONS