

Series VENTS Wave



Low-noise and low-power
extract axial fan with
air flow up to 85 m³/h

Application

- Permanent or intermittent extract ventilation of shower rooms, bathrooms, kitchens and other residential premises
- Ventilation of premises with high requirements to noise level.
- Mounting into ventilation shafts or connection to Ø 100 mm air ducts.

Design

- Modern design and aesthetic look.
- The casing, the impeller and the front panel are made of high-quality and durable UV-resistant plastic.
- The specially designed aerodynamic profile of the mixed-flow impeller provides high air flow and pressure combined with low-noise operation.
- The fan is equipped with a specially designed backdraft damper to prevent back flow and heat losses during the fan standby.
- The fan exhaust spigot incorporates specially designed air rectifiers to reduce air turbulence, noise level and boost air pressure.

Motor

- Reliable motor with low energy demand.
- Rated for continuous operation and is completely maintenance-free.
- Integrated overheating protection

Modifications and Options



Wave L: modification with a ball bearing motor for long service life (around 40 000 operating hours). Installation at any angle is possible. The ball bearings require no maintenance and are greased for the entire service life.



Wave T: modification with a regulated turn-off delay timer.



Wave T1: modification with a turn-on delay timer regulated from 10 seconds to 2 minutes and a turn-off delay timer regulated from 2 up to 30 minutes.



Wave TH: modification with a turn-off delay timer regulated from 2 up to 30 minutes and a humidity sensor regulated from 60 % up to 90 %.



Wave V: modification with a pull-cord switch.



Wave VT: modification with a pull-cord switch and a turn-off delay timer regulated from 2 up to 30 minutes.



Wave VTH: modification with a pull cord switch, turn-off delay timer regulated from 2 up to 30 minutes and a humidity sensor regulated from 60 % up to 90 %.

Mounting features

- Direct installation inside a ventilation shaft.
- Flexible air ducts may be used in case of remote location of the ventilation shaft. The air duct is connected to the exhaust spigot with a fixing clamp.
- Wall mounting with screws.
- Suitable for ceiling mounting.

Control

Manual control:

- Manual operation with a room light switch (not included in the delivery set).
- Operation with a built-in pull cord switch **V**. Not applicable in case of the ceiling mounting.

Automatic control:

- Control with the electronic control unit **BU-1-60** (see Electrical Accessories). The control unit is supplied separately.
- Control with the turn-off delay timer **T**. The built-in turn-off delay timer enables operation of the fan within 2 up to 30 minutes after turning the fan off with a switch.
- Control with the timer **T1**. After turning of the external switch the turn-on delay timer is activated for from 10 seconds to 2 minutes. The fan remains turned off. After the fan is turned off with the external switch the fan keeps running within 2 up to 30 minutes according to the settings of the turn-off delay timer.
- Control with the humidity sensor and timer **TH**. If the indoor humidity exceeds the set humidity point adjustable from 60 to 90 %, the fan switches automatically on and runs until the indoor humidity drops below the set humidity point. After that the fan continues running according to the timer settings and turns off.

Accessories



Air ducts

Grilles and hoods

Backdraft dampers

Speed controllers

Clamps

Aerodynamic characteristics

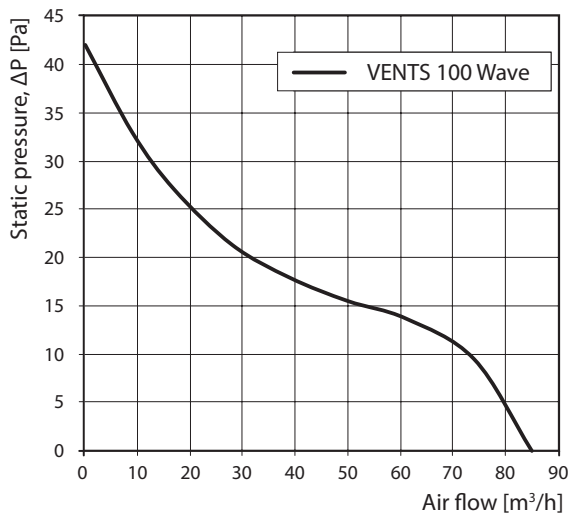

Overall dimensions

Model	Dimensions [mm]			
	Ø D	B	L	L1
VENTS 100 Wave	99	160	79	38

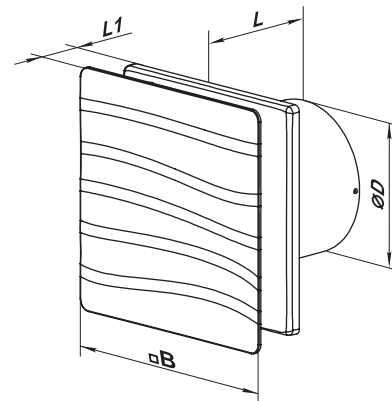

Technical data

Model	Frequency [Hz]	Voltage [V]	Power consumption [W]	Current [A]	RPM [min ⁻¹]	Maximum air flow [m³/h]	Sound Pressure Level [dBA]*	Weight [kg]	IP
VENTS 100 Wave	50	220-240	8	0.05	2000	85	27	0.51	44
VENTS 100 Wave (220 V/60 Hz)	60	220	8	0.05	2000	85	27	0.51	44

*Sound pressure level measured in free space at a distance of 3 meters from the fan.

Mounting example



Certificates

The fans meet the applicable safety and electromagnetic compatibility standards.