

TECHNICAL SPECIFICATION OF DISTRIBUTION BLOCKS, UNIVERSAL TERMINALS / TECHNISCHE DATEN DER PHASENVERTEILUNGSBLÖCKE UND DER UNIVERSALKLEMMEN / ESPECIFICACIÓN TÉCNICA DE BLOQUES DE DISTRIBUCIÓN Y DE BLOQUES UNIVERSALES

Application / Anwendung / Attention: Distribution blocks are designed to be used for electrotechnical connections of low voltage switchgear units. / Phasenverteilungsblöcke wurden entworfen, um sie fuer elektrotechnische Verbindungen mit geringem Wechselstrom zu benutzen. / Los bloques han sido diseñados para conexiones eléctricas en cuadros de baja tensión.

TERMINAL BLOCKS / PHASENVERTEILUNGSBLÖCKE / BLOQUES DE DISTRIBUCIÓN: DB SERIES / SERIE / SERIE

TYPE / TYP / TIPO	NOMINAL CROSS-SECTION / NENNQUERSCHNITT / SECCIÓN NOMINAL [mm ²]	CURRENT / STROM / INTENSIDAD DE CORRIENTE (In) [A]
DB 1, DB 2	50	160
DB 4 - DB 8	70	192
DB 12, DB 13	120, 150	269, 309

Wires terminal connections: Threaded clamping elements. Wire ends without terminals/elastic stranded conductors with sleeve terminals.

Anschlüsse der Drähte: Gedrehte Spannelemente. Drahtenden ohne Klemmen/elastische Litzenleiter mit Hülsenanschlüssen

Método de fijación de cables en en bloque: bornes de tornillo. Extremos de cables rígidos sin apretar en mangas/Extremos de cables flexibles apretados en mangas

ISOLATION MATERIAL OF HOUSINGS / GEHÄUSEISOLIERUNGWERKSTOFF / MATERIAL DE AISLAMIENTO DE CARCASAS

PA 6.6*	Color / Farbe / Kolor RAL 7035 (grey / grau / gris), RAL 5015 (blue / blau / azul), RAL 6010 (green / grün / verde)
Flame retardant / Brennbarkeit / inflamibilidad	VO class / klasse / clase**

*acc. to Restriction of Hazardous Substances (2002/95/EC) z 27.01.2003 (RoHS)

** acc. to to PN-EN 60695- 11-10; L 94

MATERIAL FOR CONDUCTING INSERTS / LEITUNGSMATERIAL / MATERIAL DE INSERTO

BRASS / MESSING / LATÓN	CuZn40Pb2*
-------------------------	------------

*acc. to DIN 17760:1983-2; EN 12164

TERMINAL BLOCKS / PHASENVERTEILUNGSBLÖCKE / BLOQUE DE DISTRIBUCIÓN: SDB SERIES / SERIE / SERIE

TYPE / TYP / TIPO	NOMINAL CROSS-SECTION / NENNQUERSCHNITT / SECCIÓN NOMINAL [mm ²]	CURRENT / STROM / INTENSIDAD DE CORRIENTE (In) [A]
SDB-25	25	100
SDB-70	70	192

Wires terminal connections: Threaded clamping elements. Wire ends without terminals/elastic stranded conductors with sleeve terminals.

Anschlüsse der Drähte: Gedrehte Spannelemente. Drahtenden ohne Klemmen/elastische Litzenleiter mit Hülsenanschlüssen

Método de fijación de cables en en bloque: bornes de tornillo. Extremos de cables rígidos sin apretar en mangas/Extremos de cables flexibles apretados en mangas

ISOLATION MATERIAL OF HOUSINGS / GEHÄUSEISOLATIONMATERIAL / MATERIAL DE AISLAMIENTO DE CARCASAS

PC ABS	Color / Farbe / Kolor RAL 7035 (grey / grau / gris), RAL 5015 (blue / blau / azul), RAL 6010 (green / grün / verde)
Flame retardant / Brennbarkeit / inflamibilidad	VO class / klasse / clase**

*acc. to Restriction of Hazardous Substances (2002/95/EC) z 27.01.2003 (RoHS)

** acc. to to PN-EN 60695- 11-10; L 94

MATERIAL FOR CONDUCTING INSERTS / LEITUNGSMATERIAL / MATERIAL DE INSERTO

BRASS / MESSING / LATÓN	CuZn40Pb2*
-------------------------	------------

*acc. to DIN 17760:1983-2; EN 12164

Our products compliant following standards / Unsere Produkte konform mit der Vorschriften / Nuestros productos cumplen con los requisitos de las normas: DIN EN 60047-1:2010; DIN EN 60947-7-1:2012;

UNIVERSAL BLOCKS / UNIVERSALKLEMMEN / BLOQUES UNIVERSALES: ZP SERIES / SERIE / SERIE

TYPE / TYP / TIPO	NOMINAL CROSS-SECTION / NENQUERSCHNITT / SECCIÓN NOMINAL [mm ²]	CURRENT / STROM / INTENSIDAD DE CORRIENTE (In) [A]
ZP-35	35	100
ZP-50	50	160

Wires terminal connections: Threaded clamping elements. Wire ends without terminals/elastic stranded conductors with sleeve terminals.

Anschlüsse der Drähte: Gedrehte Spannelemente. Drahtenden ohne Klemmen/elastische Litzenleiter mit Hülansenchlüssen

Método de fijación de cables en en bloque: bornes de tornillo. Extremos de cables rígidos sin apretar en mangas/Extremos de cables flexibles apretados en mangas

ISOLATION MATERIAL OF ENCLOSURES AND HOUSING / GEHÄUSEISOLIERUNGWERKSTOFF / MATERIAL DE AISLAMIENTO DE CARCASAS DE BLOQUES	
PA 6.6*	Color / Farbe / Kolor RAL 7035 (grey / grau / gris), RAL 5015 (blue / blau / azul), RAL 6010 (green / grün / verde)
Flame retardant / Brennbarkeit / inflamabilidad	VO class / klasse / clase**

*acc. to Restriction of Hazardous Substances (2002/95/EC) z 27.01.2003 (RoHS)

** acc. to to PN-EN 60695- 11-10; L 94

MATERIAL FOR CONDUCTING INSERTS / LEITUNGSMATERIAL / MATERIAL DE INSERTO	
ALUMINIUM*	EN AW 6060**

*aluminum with protective coating (chromium VI free), allow to connect AL/Cu / Aluminium mit Schutzbeschichtung (Chrom VI frei),
Verbindung mit AL/Cu erlaubt / set/aluminio galvanizado (sin cromo IV), que permite unir los cables de cobre con los cables de aluminio

**acc. to EN 573-1:2004

Our products compliant following standards / Unsere Produkte sind konform mit den Vorschriften / Nuestros productos cumplen con los requisitos de las normas: DIN EN 60047-1:2010; DIN EN 60947-7-1:2012;

UNIVERSAL TERMINALS AL/CU / UNIVERSALKLEMMEN AL/CU / CONECTOR AL/CU

ZP-50 AL/CU



TECHNICAL DATA / TECHNISCHE DATEN / DATOS TÉCNICOS

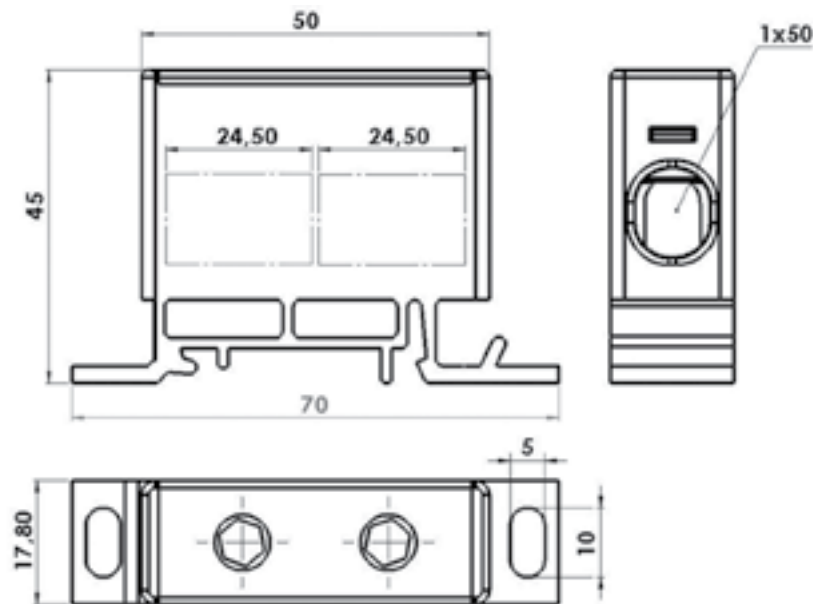

I_n	Max. current / max. Schienestrom / Capacidad de carga actual	160 [A]
U_i	Rated insulation voltage / Bemessungsisolationsspannung / Tensión nominal de aislamiento	500 [V]
U_{imp}	Surge voltage / Bemessungsschossspannung / Tensión nominal de choque tolerada	6 [kV]
	Material of insulation / Werkstoff für Insolierung / Material de aislamiento	PA6.6
	Material of insert / elektrisches Leitermaterial / Material de inserto	ALUMINIUM / ALUMINIO

TYPE TYP TIPO	CROSS-SECTION QUERSCHNITT SECCIÓN [mm ²]	AVAILABLE COLORS VERFUGBARE FARBEN COLORES DISPONIBLES	CATALOGUE NUMBER KATALOGNUMMER NÚMERO DE CATÁLOGO	PACKAGING / VERPACKUNG / EMBALAJE	
				single package / packungseinheit / embalaje individual [pcs]/[kg]	collective packaging / sammelverpackung / embalaje colectivo [pcs]/[kg]
ZP-50/SZ	50	GREY / GRAU / GRIS	0250100050101	10/0,460	300/13,80
ZP-50/N	50	BLUE / BLAU / AZUL	0250100050102	10/0,460	300/13,80
ZP-50/Z	50	GREEN / GRÜN / VERDE	0250100050103	10/0,460	300/13,80



CHARACTERISTICS OF BLOCK / EIGENSCHAFTEN VON BLOCKTERMINALS / CARACTERÍSTICAS DE ENCHUFES Y BORNES DEL BLOQUE

EXIT / ABGANG / SALIDA

Pole przekroju Cross-sectional area Querschnittsfläche [mm ²]	Wire type Drahtart Tipo de cable	Cross section of wires Querschnitt der Drähte Sección de los cables [mm ²]	Screw type Art. der Schrauben Tipo de tornillos ⊙	Max. connections Max. Anschlüsse Número de enchufes	Socket depth Sockeltiefe Profundidad de enchufe [mm]	Hexagon socket, screw keys Innensechskant, Schraubenschlüssel Tamaño de llave allen	Max. torque Max. Drehmoment Par de apriete máx. [Nm]	Fixing screw Befestigungsschraube Método de fijación TH 35 [Ø] 4
50		16-70	M10x14	2	24,60	5	10	+
		25-50	M10x14					

Quality Control:

