

PROTECTION OF PV INVERTERS



**New generation of
NH gG and gS fuse-links
for cable protection in 800V a.c.
system in standard NH sizes**

New directions in PV inverters development

New directions in PV inverters development...

PV inverters are getting larger and smarter, their characteristics better and better, they have become smart, safe, reliable and efficient.

Higher yields are reached by utilizing dynamic system efficiency optimization with intelligent technology. Achieved efficiency currently ranges above 98,5%. One of most important technical features of the new generation of PV inverters is 800V a.c. output voltage instead of 400V a.c. With this output voltage increase, we achieve a 75% decrease in a.c. connection wires losses. Yet, because of the increased output voltage modern PV central inverters demand a specially designed fuse-link for reliable short-circuit and over-current protection.

... and new fuse-links to answer the increased demands of their output protection

As one of the first among the producers of NH fuse-links, ETI has developed a new generation of NH gG fuse-links, specially designed for cable protection on 800V a.c. system voltage. With an innovative design of melting elements, adoption of high temperature and internal pressure resistant ceramic material, the final NH fuse-link construction can now be incorporated in a standard NH size dimensions.

At the moment ETI is offering sizes NH00, NH1 and NH3 gG fuse-links, from rated current 6A up to 315A, designed and tested on 800V a.c. with very low power dissipation and high breaking capacity. On a customer request, we are also ready to develop even higher rated currents.

Features and benefits

- ✓ Load switching capacity up to 800V a.c.
- ✓ Meets IEC photovoltaic standards
- ✓ In standard NH size dimensions
- ✓ Extremely low power dissipation
- ✓ High breaking capacity
- ✓ Designed to protect against a full range of overcurrents
- ✓ High temperature and internal pressure resistant ceramic material
- ✓ Innovative design of melting elements

Applications

- ✓ For cable protection on a.c. side of 1500V PV inverter



NH gPV 1000V - Fuse-links

General characteristics	
Rated voltage	1000V d.c. (NH1, 2, 3: L/R=1ms; NH0, 1C: L/R=2ms)
Breaking capacity	30kA d.c. (NH1, 2, 3), 20kA d.c. (NH0, 1C)
Standards	IEC 60269-6
Application	Fuse-link for DC application. Applied in fuse base PK1, 2, 3 1000V d.c..



NH gPV 1000V d.c.														
Size	I_n [A]	gPV Standard indicator Code No. Pic.1	gPV S_{110} screw contact Code No. Pic.2	gPV U_{110} screw contact Code No. Pic.3	gPV G screw contact with centre trip indicator for microswitch MK Code No. Pic.4	Power dissipation $(0,7 \times I_n^2)$ [W]	Power dissipation [W]	Pre-arcing Joule integral [I ² t] (L/R = 1ms)	Operating Joule integral [I ² t] (L/R = 1ms)	Weight [g]	Packaging [pcs]			
0	32	004110381	-	-	-	7,6	7,6	52	430	280	3/45			
	40	004110383	-	-	-	8,8	8,8	96	730					
	50	004110384	-	-	-	11,0	11,0	155	920					
	63	004110385	-	-	-	13,5	13,5	290	1.760					
	80	004110386	-	-	-	17,0	17,0	520	3.160					
	100	004110387	-	-	-	21,0	21,0	1.110	5.280					
	125	004110388	-	-	-	22	22	2.800	11.340					
1C	160	004110389	-	-	-	32	32	5.950	20.750	300	3/45			
	32	004110371	-	-	-	7,6	7,6	52	430					
	40	004110373	-	-	-	8,8	8,8	96	730					
	50	004110374	-	-	-	11,0	11,0	155	920					
	63	004110375	-	-	-	13,5	13,5	290	1.760					
	80	004110376	-	-	-	17,0	17,0	520	3.160					
	100	004110377	-	-	-	21,0	21,0	1.110	5.280					
1	125	004110378	-	-	-	22	22	2.800	11.340	500	3/24			
	160	004110379	-	-	-	32	32	5.950	20.750					
	200	004110342	-	-	-	11	27	4.400	29.000					
	2	200	004110343	004110292	004110296	004110346	11	26	4.400			29.000	650	1/16 (G screw contact: 2/16)
		250	004110344	004110293	004110297	004110347	15	36	6.000			38.000		
	3	160	004110456	-	-	-	15	38	5.000			10.000	1200	3/15 (G screw contact: 2/8)
		200	004110455	-	-	-	18	45	10.000			20.000		
250		004110458	-	-	-	18	44	20.000	40.000					
315		004110460	004110294	004110298	004110232	24	54	40.000	80.000					
350		004110459	004110348	004110349	004110233	25	55	45.000	90.000					
400		004110457	004110295	004110299	004110234	24	58	46.000	138.000					



NH gG 800V a.c. Fuse-links

General characteristics

Rated voltage	800V a.c.
Rated current	6A - 315A
Breaking capacity	120kA
Characteristic	gG
Standards	IEC 60269-2
Application	For cable protection on a.c. side of PV inverter

NV/NH gG 800V a.c.

Size	Breaking capacity [kA]	I _n [A]	Code No.	Pre-arcing Joule integral [A ² s]	Operating Joule integral [A ² s]	Power dissipation [0,7 x I _n] Pd [W]	Power dissipation [W]	Weight [g]	Pack. [pcs]
NH00	120	6	004184512	63	650	0,8	1,9	173	3/90
		10	004184513	35	850	0,6	1,3		
		16	004184514	120	1.800	1,1	2,4		
		20	004184515	225	4.000	1,1	2,6		
		25	004184516	300	6.500	1,2	2,7		
		35	004184518	1.800	10.000	1,5	3,3		
		40	004184519	2.100	13.500	1,8	4,0		
		50	004184520	4.300	27.000	2,1	4,8		
NH1	120	25	004184482	600	14.000	1,4	3,2	420	3/24
		35	004184483	2.400	35.000	1,5	3,4		
		40	004184484	3.200	50.000	1,8	4,0		
		50	004184485	3.500	70.000	1,9	4,4		
		63	004184486	5.500	120.000	2,4	5,5		
		80	004184487	11.000	145.000	3,0	6,9		
		100	004184488	18.000	185.000	3,8	8,6		
		125	004184489	27.000	260.000	4,3	9,7		
NH3	120	200	004184525	70.000	690.000	6,4	14,5	785	3/12
		250	004184526	110.000	1.100.000	9,7	22,0		
		315	004184498*	140.000	1.340.000	12,8	29,0		

*Top visual indicator



Recommended Accessories

- ✓ Ceramic fuse bases
- ✓ Plastic fuse bases
- ✓ Fuse disconnectors

Dimensions

Size	Dimensions [mm]								
	A	B	C	D	E	F	G	H	K
00	79	53	47	35	15	28	56	12	6
1	135	72	65	40	20	46	65	14	6
3	150	74	70	60	37	73	87	13	6
3*	150	74	70	60	37	73	87	13	6

*Top visual indicator

NH00 KOMBI

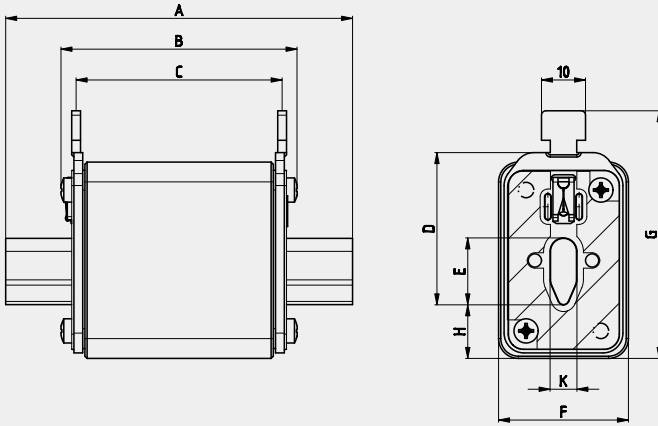

NH1, NH3 KOMBI

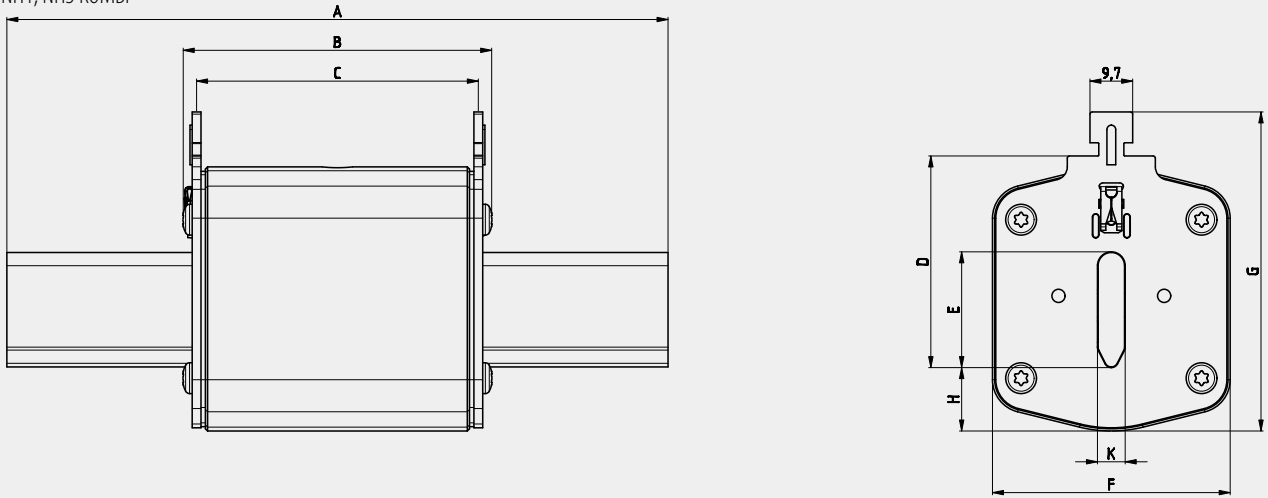

NH3

