

Applications



PROTECTION OF PV SYSTEMS



Photovoltaic String Protection

CH 10 gPV fuse selection

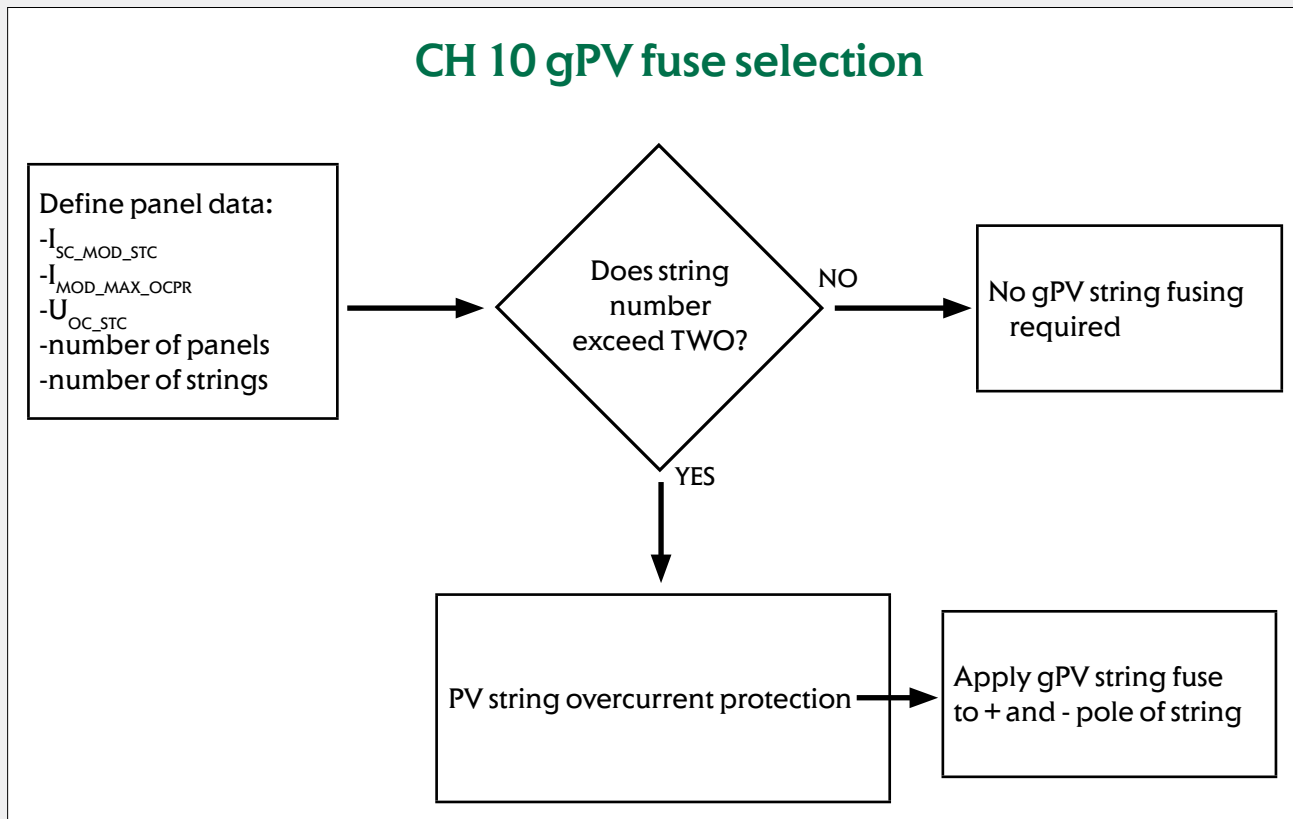

PV string overcurrent protection:

$I_n > 1,5 \times I_{SC_MOD_STC}$ – the short circuit current of a PV module or PV string st STC

$I_n < 2,4 \times I_{SC_MOD_STC}$

$I_n \leq I_{MOD_MAX_OCPR}$ – the PV module max. overcurrent protection rating

$U_n \geq 1,2 \times U_{OC_STC \times \text{No. of PV modules}}$

I_n – nominal overcurrent protection rating

U_n – nominal overcurrent protection voltage

Use temperature derating factor.

ETI as one of the most important European producer of overcurrent protection equipment and devices participating in many working groups for standards development at International Electrotechnical Commission (IEC). ETI is member of maintenance team MT9 belonging to the 32B group, working on the part 6 of the IEC 60269 dealing with supplementary requirements for fuse-links for the overcurrent protection of solar photovoltaic energy systems.

gPV fuse-link must be selected acc. standard IEC 62548

CH10 gPV 1000V - Fuse-links

General characteristics		UL file: E347771
Rated voltage	1000V d.c. L/R=2ms	
Rated current	0,5 - 25A	
Breaking capacity	10kA d.c. UL / 30kA d.c. IEC	
Standards	IEC 60269-6, UL 248-19	
Application	For protection of photovoltaic modules.	



CH10x38 gPV 1000V d.c.											
Size	Breaking capacity [kA]	I_n [A]	Code No. "standard contacts" 10kA UL	Code No. "standard contacts" 30kA IEC	Code No. "type SU contacts" 30kA IEC	Pre-arcing Joule integral [A ² s] L/R=2ms	Operating Joule integral [A ² s] L/R=2ms	Power dissipation [0,7 x I _n] ² P _d [W]	Power dissipation [I _n] ² P _d [W]	Weight [g]	Packaging [pcs]
10 x 38	UL 10kA IEC 30kA	0,5	/	002625134	002625131	0,02	0,07	0,2	0,5	10 SU: 12	10/500 SU:10/380
		1	/	002625138	002625129	1,5	3	0,4	1,0		
		2	002625101	002625065	002625115	1,7	2,3	0,5	1,1		
		3	002625100	002625067	002625113	2,8	5,4	0,7	1,6		
		3,5	002625135	002625068	002625127	2,5	7	0,6	1,4		
		4	002625102	002625069	002625116	3,9	11,7	0,5	1,3		
		5	002625111	002625070	002625124	8	21	0,6	1,5		
		6	002625103	002625071	002625117	10,6	34,6	0,7	1,8		
		7	002625110	002625072	002625114	16	60	0,7	1,7		
		8	002625104	002625073	002625118	17	65	0,8	1,9		
		10	002625105	002625075	002625119	8,3	33	1,0	2,4		
		12	002625106	002625077	002625120	22	73	0,8	1,9		
		13	002625137	002625078	002625128	21	70	1,0	2,3		
		14	002625136	002625079	002625126	28	92	1,3	3,0		
		15	002625112	002625080	002625125	49	145	1,0	2,2		
		16	002625107	002625081	002625121	48	147	1,1	2,6		
		20	002625108	002625085	002625122	86	245	1,3	3,2		
25	/	002625139	002625140	110	470	1,7	4,1				

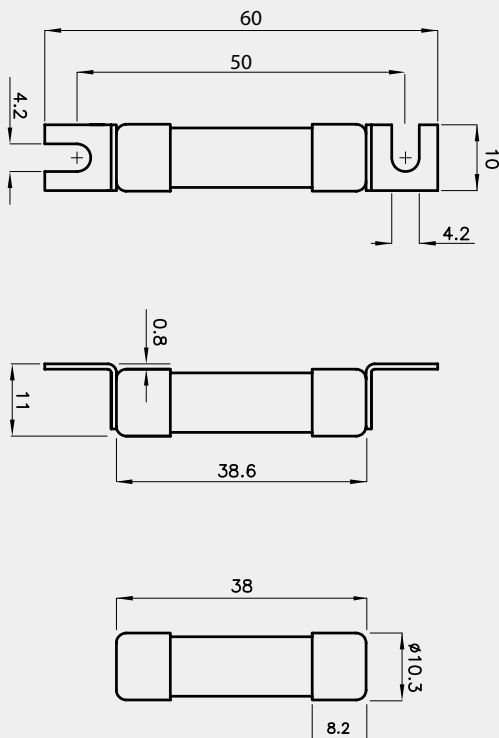

Standard Contacts

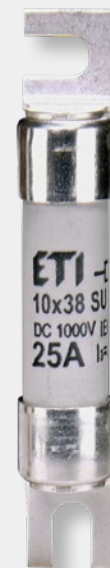

Type SU Contacts